



4-Wire Photoelectric, Low-Flow Duct Smoke Detector



Innovair™

System Sensor's Innovair DH100ACDCLP reduces the spread of smoke through HVAC air duct systems, including low-flow applications. As a photoelectric detector, it's ultra-responsive to the large smoke particles commonly found in duct systems.

The DH100ACDCLP uses low-flow technology to sense smoke in the lowest air speeds, from 100 to 4,000 feet per minute. When smoke is detected, all interconnected units will initiate their relays. However, to quickly locate the fire source, only the detector sensing smoke will alarm. Two DPDT Form-C relay contacts, connected to auxiliary equipment, can also be configured to prevent the spread of smoke through a particular area.

The DH100ACDCLP is simple to install and maintain. Powered by 24 VAC/DC or 120/240 VAC, it can be easily mounted to round and rectangular ducts, from one to twelve feet in width, with outside mounting tabs. It also offers an adjustable telescopic sampling tube that can be used for duct widths up to 18 inches. This tube locks into place – no additional tools are necessary.

Its modular construction allows for easy cleaning and field replacement of the power and sensor boards. Also simplifying maintenance is a transparent cover that provides convenient visual inspection. If the cover is removed, a patented cover-tamper trouble signal gives a 7-minute delay before the panel or remote accessory is notified of trouble.

At a remote location, the remote test station option ensures that a detector is functioning properly and the remote sounder/LED indicator option signals if a detector is in alarm. However, the cover does not need to be removed if a detector needs to be reset at the detector. Simply push the built-in reset button.

WARNING: Duct smoke detectors are **NOT** a substitute for open area smoke detectors, **NOT** a substitute for early warning detection and **NOT** a replacement for a building's regular fire detection system. Refer to NFPA 72 and 90A for additional information.

Features

- Photoelectric, low-flow technology
- An air velocity rating from 100 feet per minute to 4,000 feet per minute (5 meters per second to 20.32 meters per second)
- Patented interconnectability for multi-fan shutdown
- Two DPDT Form-C relay contacts
- 24 VAC/DC or 120/240 VAC
- Versatile mounting options
- Outside mounting tabs
- A patented telescopic sampling tube
- Modular construction
- A patented cover-tamper trouble signal
- A transparent cover
- A remote test station
- Remote sounder/LED indicator options
- A built-in reset button

Agency Listings



Innovair Duct Smoke Detector Specifications

Architectural/Engineering Specifications

The air duct smoke detector shall be a System Sensor Model DH100ACDCLP Series Duct Smoke Detector. The detector housing shall be UL listed per UL 268A specifically for use in air handling systems. The detector shall operate at air velocities of 100 feet per minute to 4000 feet per minute (0.5 to 20.32 m/sec.). The unit shall be capable of controlling up to ten (10) air handling systems when interconnected with other detectors. The detector shall be capable of providing a trouble signal in the event that the front cover is removed. It shall be capable of local testing via magnetic switch or remote testing using the SSK451 Multi-Signaling Accessory or the RTS451KEY Remote Test Station. The unit shall be reset by local reset button or remote test station. The duct smoke detector housing shall incorporate an airtight smoke chamber in compliance with UL 268A, Standard for Smoke Detectors for Duct Applications. The housing shall be capable of mounting to either rectangular or round ducts without adapter brackets. An integral filter system shall be included to reduce dust and residue effects on detector and housing, thereby reducing maintenance and servicing. Sampling tubes shall either be telescoping or be easily installed by passing through the duct housing after the housing is mounted to the duct. The unit shall provide a spacial separation of no less than ¼" (6.4 mm) and/or a physical barrier between the high and low voltage terminals. The enclosure shall meet all applicable NEC and NFPA standards regarding electrical junction boxes. Terminal connections shall be of the strip and clamp method suitable for 12–18 AWG wiring.

Physical Specifications

Size	14¾" (37 cm.) Length; 5½" (14 cm.) Width; 2¾" (7 cm.) Depth
Shipping Weight	3¾ lbs. (1.7 kg.)
Operating Temperature Range	32° to 131°F (0° to 55°C)
Storage Temperature Range	-22° to +158°F (-30° to +70°C)
Operating Humidity Range	10% to 93% relative humidity non-condensing
Air Duct Velocity	100 to 4000 ft./min. (0.5 to 20.32 m/sec.)

Electrical Ratings – DH100ACDCLP (Includes Detector)

Power supply voltage:	20-29VDC	24 VAC 50-60 Hz	120 VAC 50-60 Hz	220/240 VAC 50-60 Hz
Input capacitance:	270 µF max.	270 µF max.	N/A	N/A
Reset voltage:	3.0 VDC min.	2.0 VAC min.	10 VAC min.	20 VAC min.
Reset time (with RTS451):	.03 to 0.3 sec.	.03 to 0.3 sec.	.03 to 0.3 sec.	.03 to 0.3 sec.
Reset time (by power down):	0.6 sec. max.	0.6 sec. max.	0.6 sec. max.	0.6 sec. max.
Power up time:	34 sec. max.	34 sec. max.	34 sec. max.	34 sec. max.
Alarm response time:	2 to 17 sec.	2 to 17 sec.	2 to 17 sec.	2 to 17 sec.
Sensitivity Test:	See detector label	See detector label	See detector label	See detector label

Current Requirements (Using No Accessories)

Max. standby current	15 mA	35 mA RMS	25 mA RMS	15 mA RMS*
Max. alarm current	70 mA	125 mA RMS	35 mA RMS*	25 mA RMS*

Contact Ratings

Alarm initiation contacts (SPST)	2.0A @ 30 VAC/DC (0.6 power factor)
Alarm auxiliary contacts (DPDT)	10A @ 30 VDC; 10A @ 250 VAC

Note: Alarm auxiliary contacts must switch 100mA minimum at 5VDC. Alarm auxiliary contacts shall not be connected to initiating circuits of control panels. Use the alarm initiation contact for this purpose.

Trouble contacts (SPDT)	2.0A @ 30 VDC (resistive); 2.0A @ 125 VAC (resistive)
--------------------------------	---

Accessory Current Loads at 24 VDC

Device	Standby	Trouble	Alarm
APA451	12.5 mA Max.	n/a	30 mA Max.
PA400	0 mA	n/a	15 mA Max.
RA400Z	0 mA	n/a	10 mA Max.
RTS451/RTS451KEY	12 mA*	n/a	7.5 mA Max.
SSK451	5 mA Max.	9 mA Max.	30 mA Max.

*Note: When a unit is powered at the 120 VAC input, any combination of accessories may be used such that the given accessory loads are: 60 mA or less in the standby state; 110 mA or less in the alarm state.

Wiring Guide

System wiring diagram for 4-wire duct smoke detectors

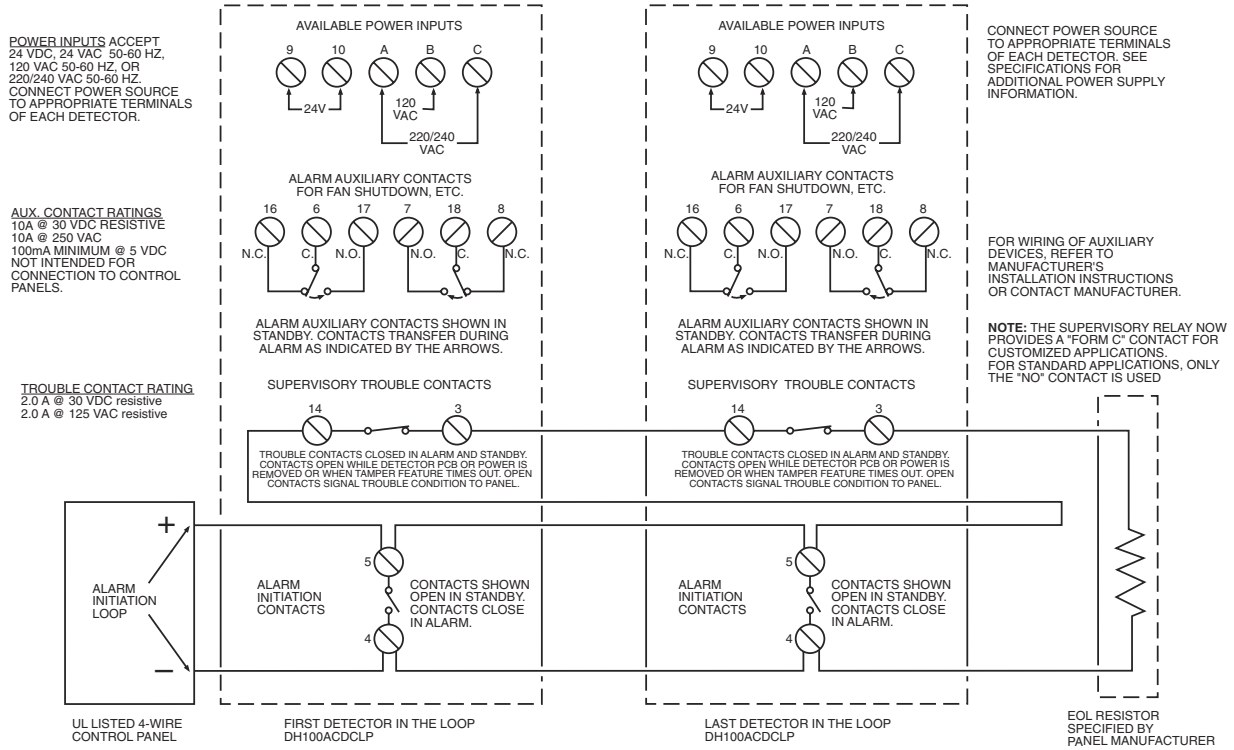

Wiring diagram for DH100ACDCLP to APA451:

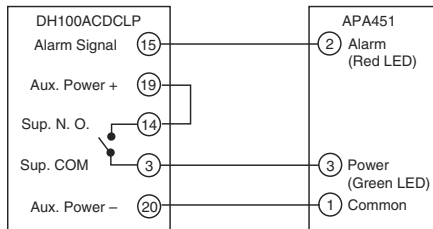

NOTE: Wiring diagram shown is for DH100ACDCLP 4-wire duct smoke detector system equipped without a control panel.

NOTE: A trouble condition is indicated when the green LED is not illuminated.

Wiring diagram for the DH100ACDCLP to RTS451/RTS451KEY:

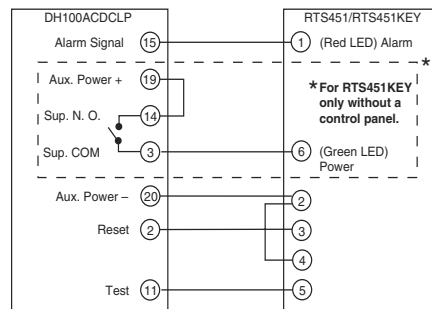

***NOTE: For RTS451KEY only without a Control Panel.**

RTS451 does not have a terminal 6.

NOTE: Wiring diagram shown is for DH100ACDCLP 4-wire duct smoke detector system equipped without a control panel.

NOTE: A trouble condition is indicated when the green LED is not illuminated.

Wiring diagrams for optional accessories:

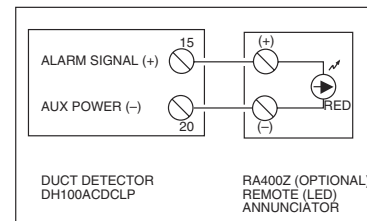
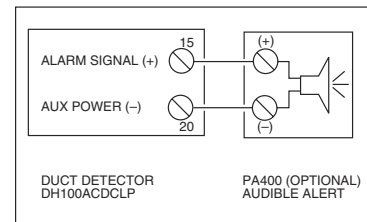

Wiring diagram for DH100ACDCLP to SSK451:

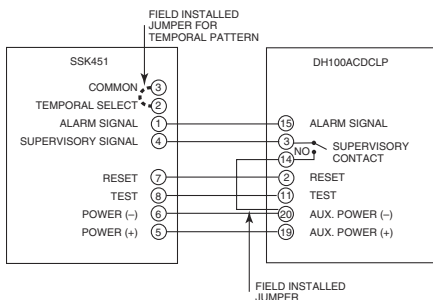

Important Interconnect Notes

- When using the interconnect feature, all interconnected units must be powered with the same, independent supply.
- Polarity must be maintained throughout the interconnect wiring. Connect terminal 12 on unit 1 to terminal 12 on unit 2 and so on. Similarly, connect terminal 1 on unit 1 to terminal 1 on unit 2 and so on.
- Up to 10 units may be interconnected.

Accessories

System Sensor provides system flexibility with a variety of accessories, including two remote test stations, and several different means of visible and audible system annunciation. As with our duct detectors, all duct smoke detector accessories are UL listed.



APA451
Piezo Annunciator
(UL S4011)



RTS451KEY
Remote Test Station
with Key (UL S2522)



PA400W
Mini-Alert Sounder
(UL S3593)
shown with PS24LOW add-on
strobe (PS12/24SLENSW smoke
lens option available)



RTS451
Remote Test Station
(UL S2522)



RA400Z
Remote Annunciator
(UL S2522)



SSK451
Multi-Signaling
Accessory
(UL 268A)



SSK451
Multi-Signaling Accessory
(UL 268A)
shown with PS24LOW add-on
strobe (PS12/24SLENSW smoke
lens option available)

Ordering Information

Part No.	Description
DH100ACDCLP	4-wire photoelectric duct detector with low-flow technology
A5190	Replacement 4-wire photoelectric detector board
A5064	Replacement 4-wire power board
Accessories	
ST-1.5	Metal sampling tube duct widths 1'-2' (0.3-0.6 m)
ST-3	Metal sampling tube duct widths 2'-4' (0.6-1.2 m)
ST-5	Metal sampling tube duct widths 4'-8' (1.2-2.4 m)
ST-10	Metal sampling tube duct widths 8'-12' (2.4-3.7 m)
T80-71-00	Replacement telescoping sampling tube
P48-55-00	Replacement end cap for T80-71-00
SSK451	Multi-Signaling accessory
RTS451KEY	Remote test station with key lock
RTS451	Remote test station
APA451	Remote annunciator with piezo alarm
MOD400R	Sensitivity test module
RA400Z	Remote annunciator alarm LED
F36-09-11	Replacement air filters (two per package)
M02-04-00	Test magnet
P48-21-00	End cap for metal sampling tubes
S08-39-01	Photo replacement screen
PA400W	Mini-Alert sounder
PS24LOW	Mini-Alert add-on strobe
PS12/24SLENSW	Wall-mount "SMOKE" lens
PS12/24SLENSC	Ceiling-mount "SMOKE" lens



3825 Ohio Avenue • St. Charles, IL 60174
Phone: 800-SENSOR2 • Fax: 630-377-6495

©2006 System Sensor.
Product specifications subject to change without notice. Visit systemsensor.com for
current product information, including the latest version of this data sheet.
A05-1044-007 • 7/06 • #1676