



333 Bayview Avenue  
Amityville, New York 11701  
For Sales and Repairs, (800) 645-9445  
For Technical Service, (800) 645-9440

© 1999

## GEM-TRANS2 Window/Door Transmitter INSTALLATION INSTRUCTIONS

WI747B 4/99

### GENERAL DESCRIPTION

The GEM-TRANS2 is a 2-point window/door transmitter designed for use in Napco GEM-series wireless systems. When used with the supplied magnet, the transmitter functions as a window/door sensor. However, terminals are provided for normally-closed external contacts so that one or two additional devices may be used in conjunction with, or instead of, the internal reed switch. A jumper option is provided to allow a normally-open external contact to be used. This allows the use of one external contact instead of the internal reed switch.

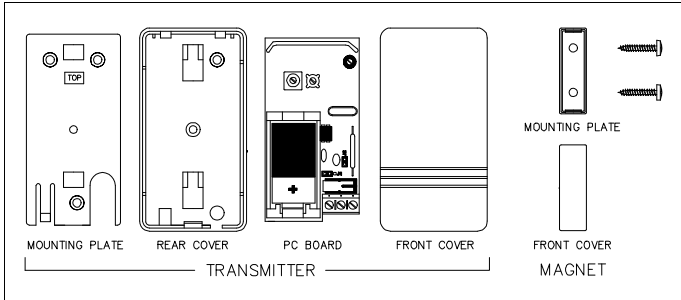

Fig. 1. GEM-TRANS2 Component Parts

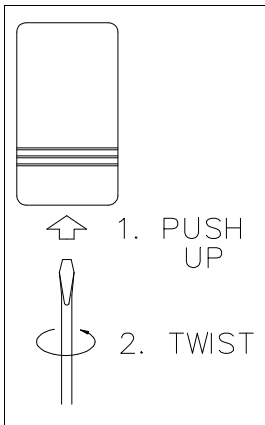

Fig. 2 Opening the case

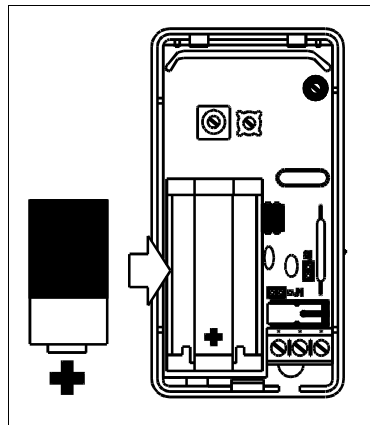

Fig. 3 Installing the battery

The GEM-TRANS2 is powered by a 3-volt Type DL123A lithium battery, which will power the transmitter for up to 5 years. When battery voltage drops below normal, a low-battery report will be sent to the receiver.

Each transmitter has a unique factory-programmed code (printed on the battery holder and also on the rear case) that distinguishes itself to the receiver. (Note: See control-panel instructions for entering this six-digit hexadecimal code and its checksum digit into the panel; be sure to enter all numbers and/or letters, including leading zeros, if any.)

### INSTALLATION

**Note:** The transmitter and magnet may be mounted in any position with no degradation in performance. Thus, if a left-handed reed switch is required, the unit may be mounted upside down. However, for reference purposes in this text, the transmitter will be considered oriented with the antenna at the top, as shown in these illustrations.

1. Remove the cover. Remove the GEM-TRANS2 transmitter cover by inserting a small screwdriver into the slot at the bottom and twisting while applying upward pressure. See Fig. 2 below.
2. Insert the battery. Observe battery polarity. Insert battery with positive (+) terminal toward terminal block. See Fig. 3. The battery will not make contact if inserted backwards.
3. Identify transmitter parts. Refer to Fig. 4.
4. Select transmitter location. Choose a location for the transmitter. Avoid mounting the transmitter near the floor. Low level mounting can reduce transmission range and may subject the transmitter to damage.
5. Remove transmitter and magnet mounting plates. Transmitter: Use a small screwdriver to push in retaining tab (Fig. 6) and slide cover upward. Magnet: Insert small screw driver into slot at either

end of magnet cover. Push in and twist to pop off cover. If using external contacts, skip to Step 7.

6. Attach mounting plates. **Note:** While use of the transmitter mounting plate is recommended, mounting holes in the rear case allow mounting without the plate. Use #6 flat-head screws to affix the mounting plates, observing alignment marks shown in Fig. 6. Mount the magnet within 1" from the transmitter. Snap transmitter and magnet onto their mounting plates. For internal contacts, skip to Step 9.

7. (For external contacts only.) Install contact or sensor and transmitter mounting plate (if used). Mount the external contact or sensor as described in its instructions. For recessed wiring, drill an access hole for the wire.

8. (For external contacts only.) Connect to terminals. Connect two wires from an external sensor having normally-closed contacts (or a normally-closed loop) to Point-1 (Terminals 1-2). Similarly, if required, connect a sensor (or loop) to Point-2 (Terminals 2-3).

9. Complete transmitter setup. Install Jumper J2 (see Fig. 4) to enable the holdoff timer (after triggering, unit waits 3 minutes before retriggering). For example, if used on doors in heavy traffic areas, this will prevent multiple alarms and thereby conserve battery life.

**Note:** If J2 is installed, both points will be delayed 3 minutes before retriggering.

If internal reed switch is used, remove Jumper J1 (see Fig. 4) and short Point-1 (Terminals 1-2). An external contact may be connected to point 2.

10. Close the transmitter case. Close the case by engaging the hooks at the top, then snap the bottom together.

11. Program the panel. Enter (a) the zone number to which the transmitter will be mapped; (b) the 6-digit ID code with checksum digit; and (c) the wireless point number. Refer to the programming instructions for the control panel and keypad in use. **Note:** In UL burglary installations, program the burglary alarm output for all protective devices.

### WIRING

The GEM-TRANS2 may be wired in any of the following configurations. Refer to the following diagrams:

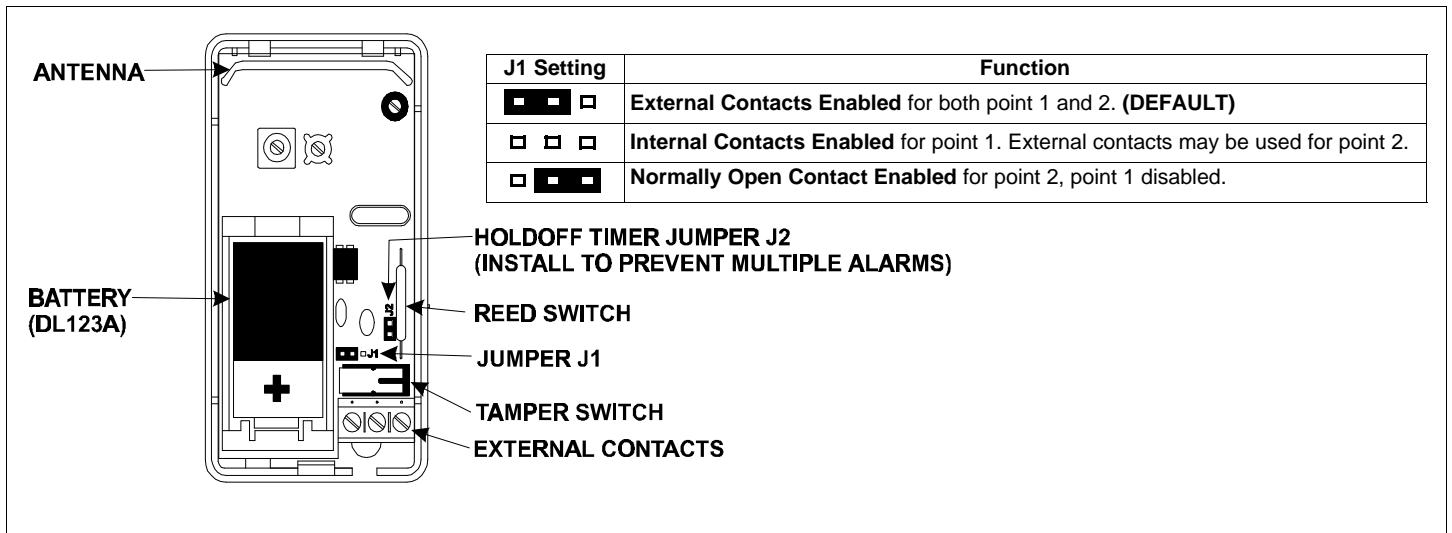

Fig. 4 Location of parts

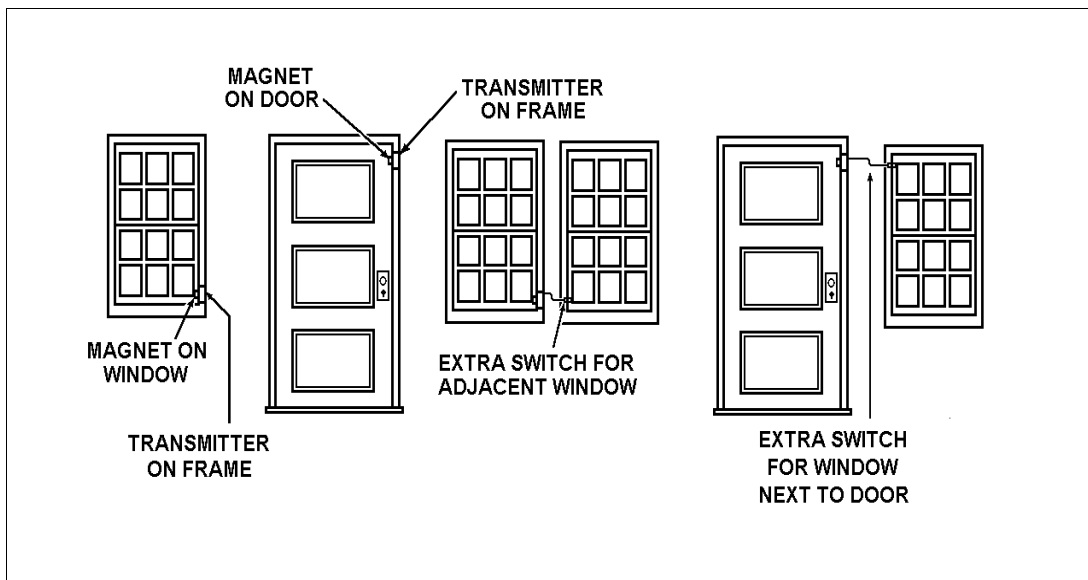

Fig. 5 Typical Transmitter Locations

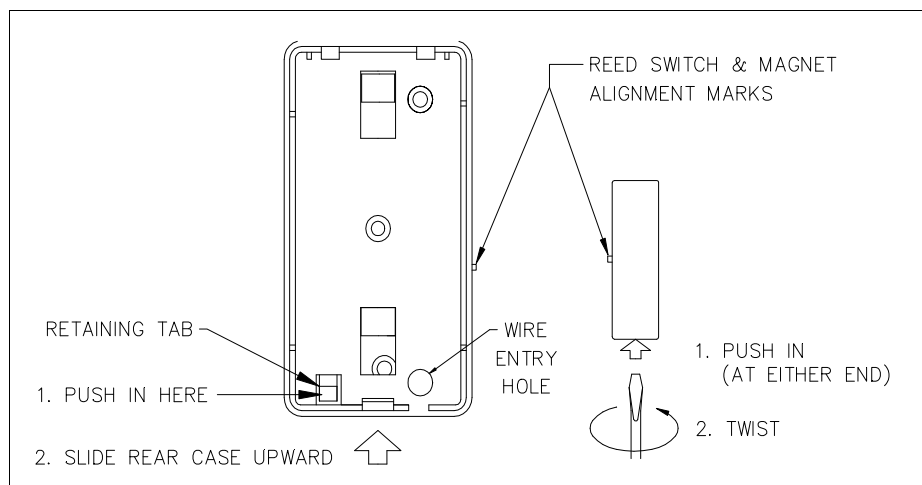
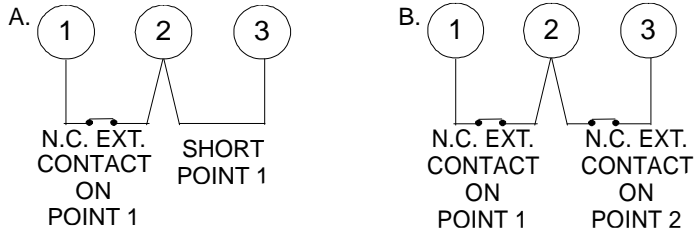

Fig. 6 Removing Mounting Plate and Magnet Cover

1.

J1 Setting	Function
<input checked="" type="checkbox"/> <input type="checkbox"/> <input type="checkbox"/>	External Contacts Enabled for both point 1 and 2. (DEFAULT)



2.

J1 Setting	Function
<input type="checkbox"/> <input type="checkbox"/> <input checked="" type="checkbox"/>	Internal Contacts Enabled for point 1. External contacts may be used for point 1 or point 2.

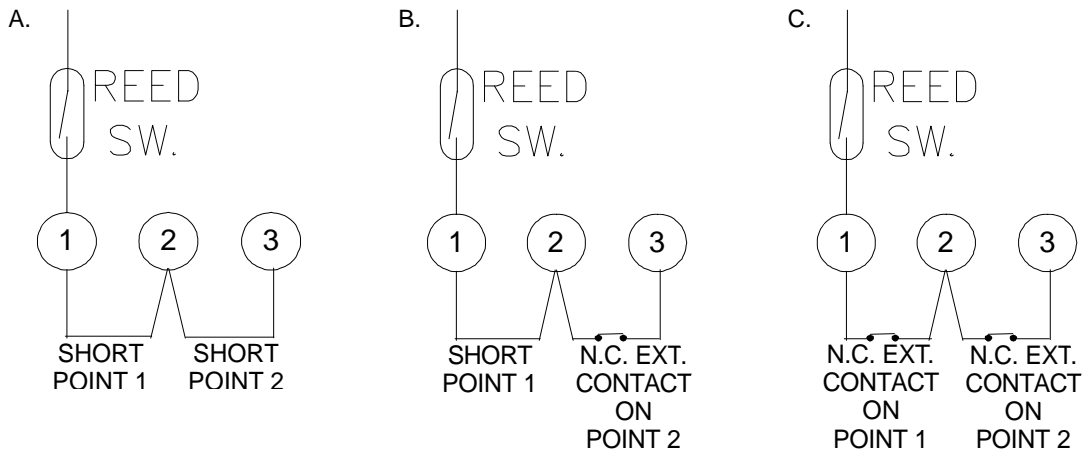

3.

J1 Setting	Function
<input type="checkbox"/> <input checked="" type="checkbox"/> <input type="checkbox"/>	Normally Open Contact Enabled for point 2, point 1 disabled.

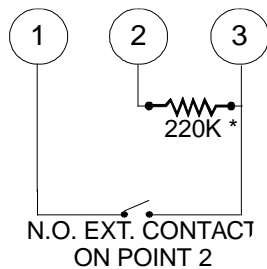

\* **Note:** The supplied 220K Ohm resistor must be used in series as shown. If a short is applied directly to the terminals in the N.O. mode, battery life will be greatly reduced during an alarm.

## NAPCO SECURITY LIMITED WARRANTY



NAPCO SECURITY SYSTEMS, INC. (NAPCO) warrants its products to be free from manufacturing defects in materials and workmanship for *thirty-six months* following the date of manufacture. NAPCO will, within said period, at its option, repair or replace any product failing to operate correctly without charge to the original purchaser or user.

This warranty shall not apply to any equipment, or any part thereof, which has been repaired by others, improperly installed, improperly used, abused, altered, damaged, subjected to acts of God, or on which any serial numbers have been altered, defaced or removed. Seller will not be responsible for any dismantling or reinstallation charges.

THERE ARE NO WARRANTIES, EXPRESS OR IMPLIED, WHICH EXTEND BEYOND THE DESCRIPTION ON THE FACE HEREOF. THERE IS NO EXPRESS OR IMPLIED WARRANTY OF MERCHANT ABILITY OR A WARRANTY OF FITNESS FOR A PARTICULAR PURPOSE. ADDITIONALLY, THIS WARRANTY IS IN LIEU OF ALL OTHER OBLIGATIONS OR LIABILITIES ON THE PART OF NAPCO.

Any action for breach of warranty, including but not limited to any implied warranty of merchant ability, must be brought within the six months following the end of the warranty period.

IN NO CASE SHALL NAPCO BE LIABLE TO ANYONE FOR ANY CONSEQUENTIAL OR INCIDENTAL DAMAGES FOR BREACH OF THIS OR ANY OTHER WARRANTY, EXPRESS OR IMPLIED, EVEN IF THE LOSS OR DAMAGE IS CAUSED BY THE SELLER'S OWN NEGLIGENCE OR FAULT.

In case of defect, contact the security professional who installed and maintains your security system. In order to exercise the warranty, the product must be returned by the security professional, shipping costs prepaid and insured to NAPCO. After repair or replacement, NAPCO assumes the cost of returning products under warranty. NAPCO shall have no obligation under this warranty, or otherwise, if the product has been repaired by others, improperly installed, improperly used, abused, altered, damaged, subjected to accident, nuisance, flood, fire or acts of God, or on which any serial numbers have been altered, defaced or removed. NAPCO will not be responsible for any dismantling, reassembly or reinstallation charges.

This warranty contains the entire warranty. It is the sole warranty and any prior agreements or representations, whether oral or written, are either merged herein or are expressly canceled. NAPCO neither assumes, nor authorizes any other person purporting to act on its behalf to modify, to change, or to assume for it, any other warranty or liability concerning its products. In no event shall NAPCO be liable for an amount in excess of NAPCO's original selling price of the product, for any loss or damage, whether direct, indirect, incidental, consequential, or otherwise arising out of any failure of the product. Seller's warranty, as herein above set forth, shall not be enlarged, diminished or affected by and no obligation or liability shall arise or grow out of Seller's rendering of technical advice or service in connection with Buyer's order of the goods furnished thereunder.

NAPCO RECOMMENDS THAT THE ENTIRE SYSTEM BE COMPLETELY TESTED WEEKLY.

Warning: Despite frequent testing, and due to, but not limited to, any or all of the following; criminal tampering, electrical or communications disruption, it is possible for the system to fail to perform as expected. NAPCO does not represent that the product/system may not be compromised or circumvented; or that the product or system will prevent any personal injury or property loss by burglary, robbery, fire or otherwise; nor that the product or system will in all cases provide adequate warning or protection. A properly installed and maintained alarm may only reduce risk of burglary, robbery, fire or otherwise but it is not insurance or a guarantee that these events will not occur. CONSEQUENTLY, SELLER SHALL HAVE NO LIABILITY FOR ANY PERSONAL INJURY, PROPERTY DAMAGE, OR OTHER LOSS BASED ON A CLAIM THE PRODUCT FAILED TO GIVE WARNING. Therefore, the installer should in turn advise the consumer to take any and all precautions for his or her safety including, but not limited to, fleeing the premises and calling police or fire department, in order to mitigate the possibilities of harm and/or damage.

NAPCO is not an insurer of either the property or safety of the user's family or employees, and limits its liability for any loss or damage including incidental or consequential damages to NAPCO's original selling price of the product regardless of the cause of such loss or damage.

Some states do not allow limitations on how long an implied warranty lasts or do not allow the exclusion or limitation of incidental or consequential damages, or differentiate in their treatment of limitations of liability for ordinary or gross negligence, so the above limitations or exclusions may not apply to you. This Warranty gives you specific legal rights and you may also have other rights which vary from state to state.