

INSTALLATION GUIDE

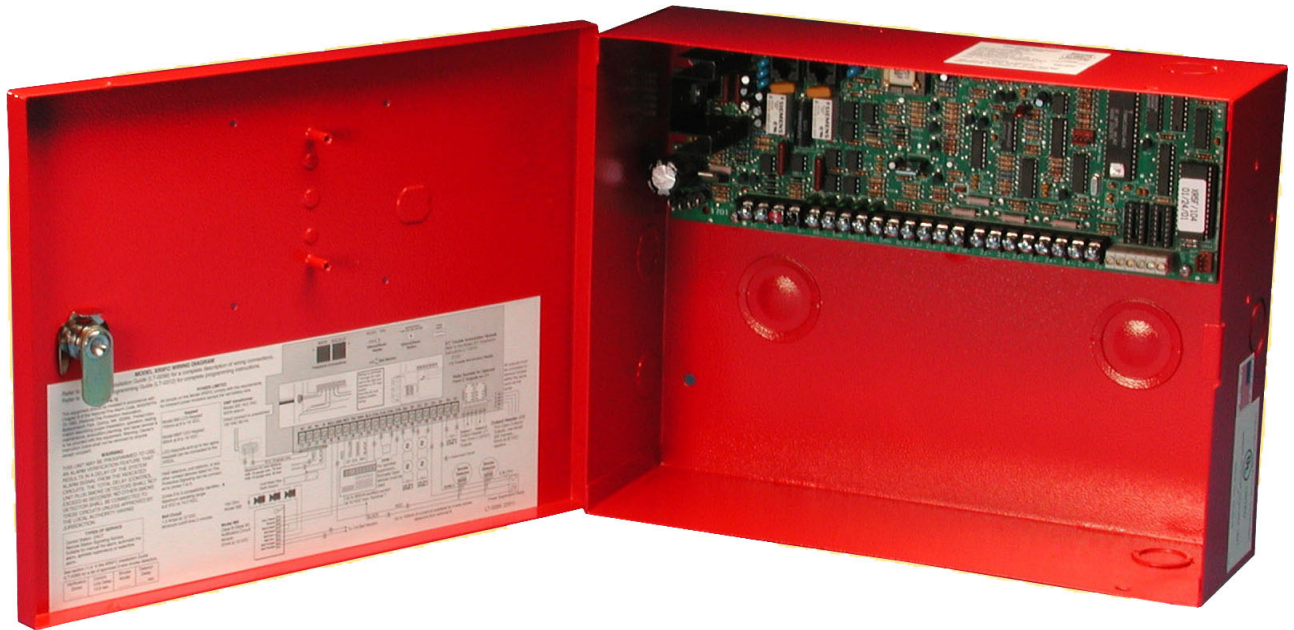

XR5FC AND XR5SL COMMERCIAL FIRE PANELS

MODEL XR5FC/XR5SL COMMAND PROCESSOR INSTALLATION GUIDE

FCC NOTICE

This equipment generates and uses radio frequency energy and, if not installed and used properly in strict accordance with the manufacturer's instructions, may cause interference with radio and television reception. It has been type tested and found to comply with the limits for a Class B computing device in accordance with the specification in Subpart J of Part 15 of FCC Rules, which are designed to provide reasonable protection against such interference in a residential installation. If this equipment does cause interference to radio or television reception, which can be determined by turning the equipment off and on, the installer is encouraged to try to correct the interference by one or more of the following measures:

- Reorient the receiving antenna

- Relocate the computer with respect to the receiver

- Move the computer away from the receiver

- Plug the computer into a different outlet so that computer and receiver are on different branch circuits

If necessary, the installer should consult the dealer or an experienced radio/television technician for additional suggestions. The installer may find the following booklet, prepared by the Federal Communications Commission, helpful:

"How to identify and Resolve Radio-TV Interference Problems."

This booklet is available from the U.S. Government Printing Office, Washington D.C. 20402

Stock No. 004-000-00345-4

Copyright © 1995 - 2008 Digital Monitoring Products, Inc.

Information furnished by DMP is believed to be accurate and reliable.

This information is subject to change without notice.

Panel Specifications	
1.1	Power Supply 1
1.2	Communication 1
1.3	Panel Zones 1
1.4	Remote Annunciators (Alphanumeric or LED Keypads) 1
1.5	Auxiliary Outputs..... 1
1.6	Push-Button Reset..... 1
1.7	Enclosure Specifications..... 1
Introduction	
2.1	Description 2
2.2	Zone Expansion..... 2
2.3	Caution Notes 2
2.4	Compliance Instructions..... 2
System Components	
3.1	Description 3
3.2	XR5FC Wiring Diagram..... 3
3.3	XR5SL Wiring Diagram..... 4
3.4	Lightning Protection..... 4
3.5	Keypads..... 4
Installation	
4.1	Mounting the Enclosure 5
4.2	Model 377 Trouble Annunciator Module..... 5
4.3	Mounting Keypads 5
4.4	Wiring Specifications for the Keypad Bus..... 6
4.5	Terminal Wiring Connections 6
Primary Power Supply	
5.1	Installing the Transformer 7
5.2	Terminals 1 and 2..... 7
Secondary Power Supply	
6.1	Battery Terminals 3 and 4 8
6.2	Earth Ground 8
6.3	Replacement Period..... 8
6.4	Discharge/Recharge 8
6.5	Battery Supervision 8
6.6	XR5FC and XR5SL Power Requirements 9
6.7	XR5FC and XR5SL Standby Battery Calculations..... 9
Bell Output	
7.1	Terminal 5 (XR5FC Only).....10
4-Wire Smoke Detector Power	
8.1	Terminal 6 (XR5FC Only).....10
Keypad Bus	
9.1	Description10
9.2	Terminal 7 - RED10
9.3	Terminal 8 - YELLOW10
9.4	Terminal 9 - GREEN10
9.5	Terminal 10 - BLACK.....10
Class A (Style D) Fire Zone	
10.1	Description10
Class B (Style A) Fire Zones	
11.1	Description11
11.2	Operational Parameters11
11.3	Zone Response Time11
11.4	Compatible 2-Wire Smoke Detectors11

TABLE OF CONTENTS

Form C Relay Outputs

12.1	Description	12
------	-------------------	----

Annunciator Outputs

13.1	Description	12
13.2	Harness Wiring.....	12

Telephone RJ Connector

14.1	Description	12
14.2	FCC Registration.....	12
14.3	Notification	13

Reset Jumper J9

15.1	Description	13
------	-------------------	----

Silence/Reset Button

16.1	Silence/Reset Button	13
16.2	Bell Circuit Monitor	13

Dual Phone Line Connectors

17.1	Description	13
------	-------------------	----

Listed Compliance Specifications

18.1	Introduction.....	14
------	-------------------	----

Universal Fire Alarm Specifications

19.1	Introduction.....	14
19.2	Wiring	14
19.3	Police Station Phone Number	14
19.4	System maintenance	14
19.5	Audible alarm (XR5FC only).....	14
19.6	Listed Receivers	14

Control Units for Fire-Protective Signaling Systems

ANSI/UL 864, NFPA 72

20.1	Power Supply	14
20.2	Power Fail delay	14
20.3	Central Station Signaling Systems.....	14
20.4	Local Protective Signaling Systems.....	14
20.5	Remote Station Protective Signaling Systems.....	14
20.6	Remote Annunciators.....	15
20.7	Notification Appliances	15
20.8	Cross Zoning	15
20.9	Ground Fault.....	15

California State Fire Marshal Specifications

21.1	Bell Output Definition	15
------	------------------------------	----

Wiring Diagrams

22.1	866 with NAC Extender	16
22.2	866 Class B Style W using Single Notification Appliance.....	17
22.3	866 Class B Style W using Multiple Notification Appliances.....	18
22.4	866 Class B Style W Multiple Notification Appliance Circuits	19
22.5	865 Class B Style W using Single Notification Appliance.....	20
22.6	865 Class B Style W Multiple Notification Appliances	21
22.7	865 Class B Style W Multiple Notification Appliance Circuits	22
22.8	865 Class A Style X using Single Notification Appliance.....	23
22.9	Remote Station Reversing Relay Connection	24
22.10	Supervised Remote Relay.....	25
22.11	XR5SL Connection to FACP.....	26

Revisions to This Document

Listings and Approvals

Panel Specifications

1.1 Power Supply

Primary Power Input: 16.5 VAC 40 VA (Model 320 wire-in) or 12/24 VDC from Fire Alarm Control Panel (FACP)

Standby Battery: One or two 12 VDC batteries

Auxiliary Output: 500mA at 12 VDC

Bell Output: .6 Amps at 12 VDC (XR5FC only)

Smoke Detector Output: 100mA at 12 VDC (XR5FC only)

All circuits inherent power limited except the red battery wire.

* For Commercial Fire installations, see the Compliance Instructions section.

1.2 Communication

Built-in SDLC Digital Dialer communication to DMP Model SCS-1R Receivers.

Built-in CID communication to non-DMP (Contact ID) receivers.

Can operate as a local system (XR5FC only).

1.3 Panel Zones

One Class A (Style D) zone (terminals 11 to 14).

Four 3.3K Ohm EOL Class B (Style A) powered fire zones with reset capability (terminals 15 to 22).

1.4 Remote Annunciators (Alphanumeric or LED Keypads)

Connect 630F keypads and LED keypads to the XR5FC and XR5SL keypad bus.

1.5 Auxiliary Outputs

Two Form C (SPDT) outputs (Outputs 1 and 2). Each output requires one Model 305 plug-in relay. Each relay is rated for 1 Amp at 30 VDC.

Four open collector annunciator outputs (Outputs 1 to 4). No relay is required. Each output is rated for 50mA at 30 VDC resistive.

1.6 Push-Button Reset

The XR5FC and XR5SL panels each provide a push button mounted on the printed circuit board that allows authorized users to reset latch detectors and silence active alarm bell outputs. See section 16.1.

1.7 Enclosure Specifications

The XR5 panels are shipped in an enclosure with End-of-Line resistors, battery leads, User's Guide (LT-0296), and Programming Sheet (LT-0297).

Size: 12.5" W x 9.5" H x 3.75" D

Weight: 4 lbs

Color: Red

Construction: 20-gauge cold-rolled steel

Introduction

2.1 Description

The DMP XR5FC and XR5SL Commercial Fire Panels are powerful 12 VDC fire alarm communicators with battery backup that can also be powered from the 12 or 24 VDC auxiliary output of a Fire Alarm Control Panel (FACP). Each panel provides one Class A (Style D) fire zone and four Class B (Style A) powered fire zones with reset capability for 2-wire smoke detectors, relays, or other latching devices.

In order to power the XR5 from the 12 VDC or 24 VDC of an FACP, the FACP must operate as a grounded control panel. If the FACP is a non-grounded system, it may detect a ground fault when connected to the XR5 panel AC or DC Input terminals. In this case the XR5 should be powered from a separate 320 wire-in transformer and not from the FACP.

The XR5 panels can communicate to one or two DMP SCS-1R Receivers using SDLC digital dialer or up to two non-DMP (Contact ID) receivers using the CID reporting format.

2.2 Zone Expansion

Up to 4 additional zones are available on the XR5 Series using a 714 or 715 zone expansion module. The panel keypad data bus supports one supervised device address with up to four programmable expansion zones. The four zone numbers are 31-34.

Note: Do not use shielded wire for Keypad Bus circuits.

2.3 Caution Notes

Throughout this guide there are caution notes containing information about installing the panel. These cautions are indicated with a yield sign. Whenever you see a caution note, make sure you completely read and understand its information. Failing to follow the caution note can cause damage to the equipment or improper operation of one or more components in the system. See the example shown below.



Always ground the panel before applying power to any devices: The XR5FC must be properly grounded before connecting any devices or applying power to the panel. Proper grounding protects against Electrostatic Discharge (ESD) that can damage system components.

2.4 Compliance Instructions

For applications that must conform to a local authorities installation standard or a National Recognized Testing Laboratory certificated system, please see the Wiring Diagrams for Notification Appliances and the Listed Compliance Specifications section near the end of this guide for additional instructions.

System Components

3.1 Description

A basic XR5 system is made up of the alarm panel with built-in communicator, an enclosure, a 16.5 VAC wire-in transformer, and a 12 VDC 7.0 Ah battery. You can add up to two alphanumeric keypads and one or more LED keypads to the panel and also connect control and annunciating devices to the panel Form C and annunciator outputs. Refer to the Power Requirements section in this guide when calculating power requirements.

3.2 XR5FC Wiring Diagram

The XR5FC system below shows some of the accessory devices for use in various applications.

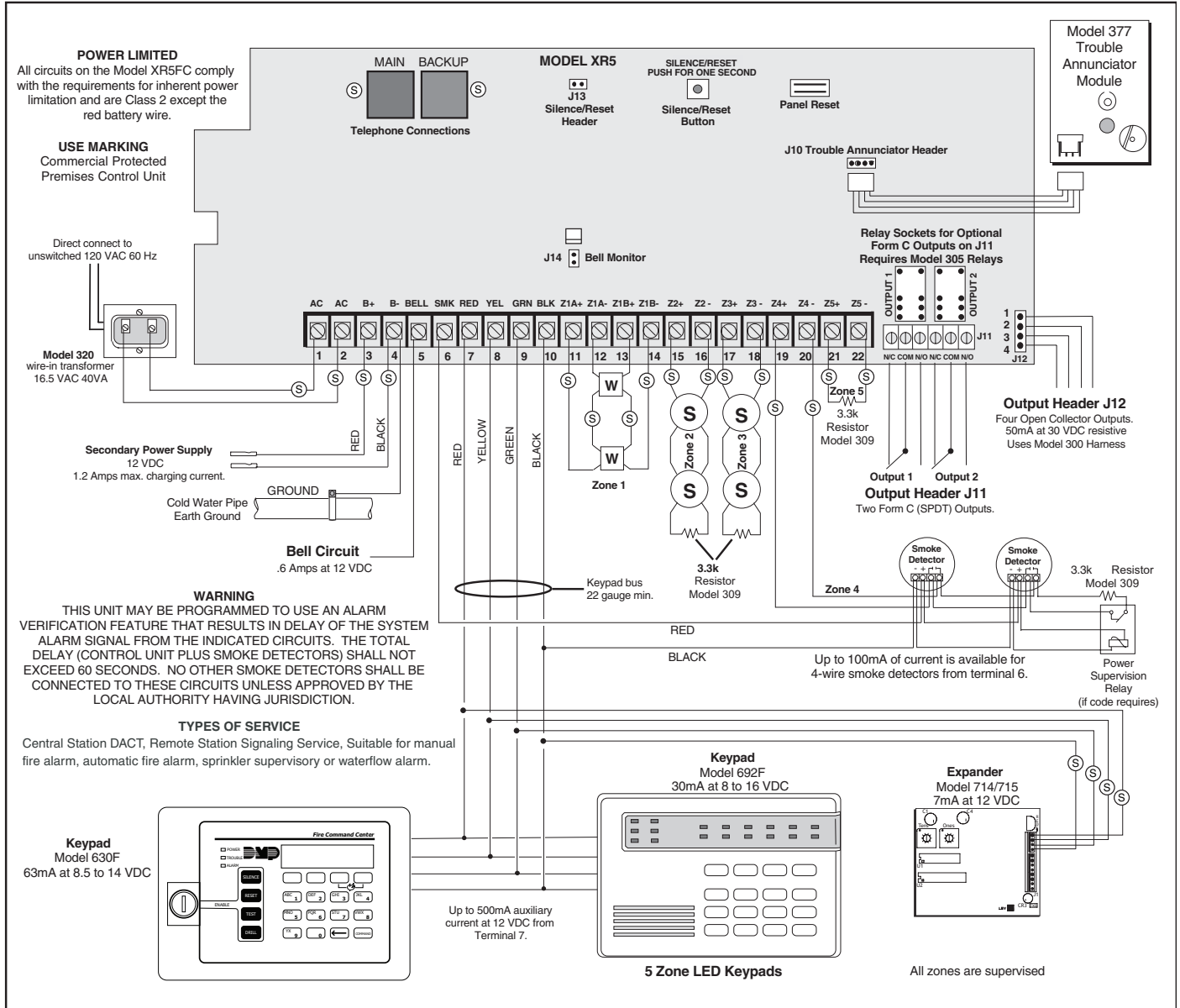

Figure 1: XR5FC Wiring Diagram

INTRODUCTION

3.3 XR5SL Wiring Diagram

The XR5SL system below shows some of the accessory devices for use in various applications.

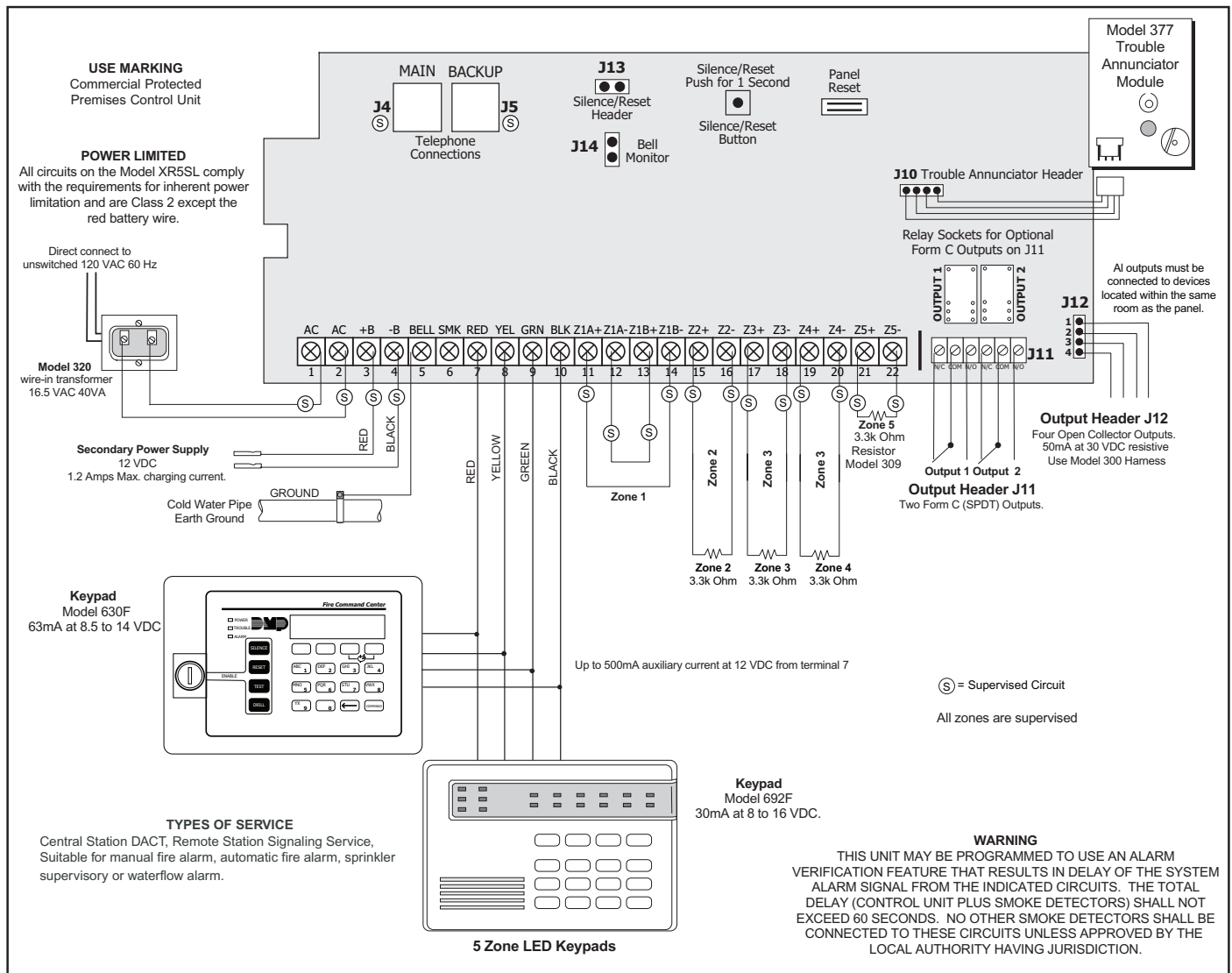

Figure 2: XR5SL Wiring Diagram

3.4 Lightning Protection

Metal Oxide Varistors and Transient Voltage Suppressors on the panel help protect against voltage surges on input and output circuits of the XR5 panels. Additional surge protection is available by installing the DMP 370 or 370RJ Lightning Suppressors.

3.5 Keypads

You can connect the Models 630F or 692F keypads to the 4-wire keypad bus provided by the panel on terminals 7, 8, 9, and 10. Do not use shielded wire for the keypad bus.

Installation

4.1 Mounting the Enclosure

Mount the metal enclosure for the XR5FC and XR5SL panels in a secure, dry place to protect the panels from damage due to tampering or the elements. It is not necessary to remove the XR5FC or XR5SL PCB when installing the enclosure.

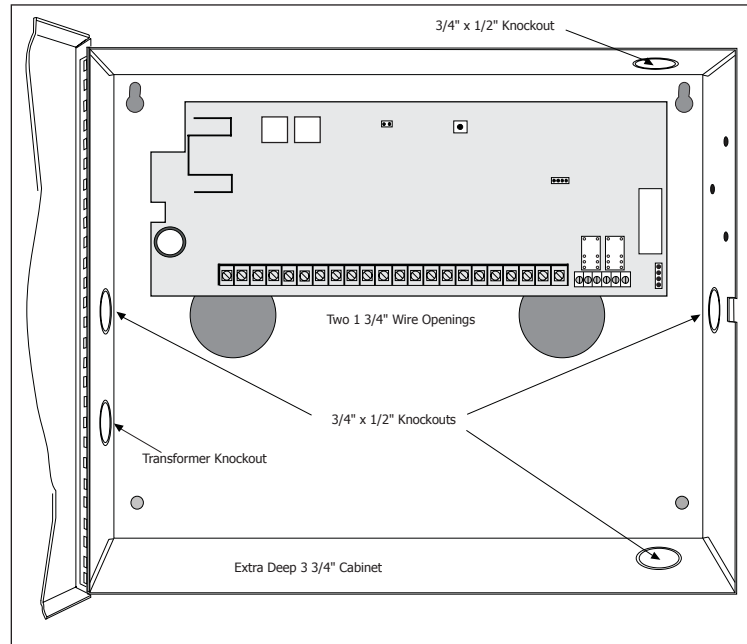

Figure 3: Mounting the Enclosure

4.2 Model 377 Trouble Annunciator Module

The 377 Module is installed on the enclosure door and connects to the panel through a 4-wire harness supplied with the module. See Figure 4.

377 Module Operation

The 377 Trouble Annunciator Module provides visual and audible annunciation of System Okay, communication trouble, and panel processor failure. The module contains a Green LED for System Okay, a Yellow LED for Trouble, an electronic sounder, and a Silence switch.

System Okay

When both phone lines are normal and the panel processor is operating, only the Green LED on the 377 Module is on. This LED goes off during a Sensor Reset.

Communication Trouble

If either phone line connected to the panel is in a bad condition, or if the panel has made TEN failed attempts to send a report to the central station receiver, the 377 Module emits a steady audible alert and turns on the Yellow LED. The Silence switch can be used to turn off the sounder only.

Panel Processor Failure

During a processor failure on the panel, or a remote programming session, the 377 Module emits a steady audible alert and turns on the Yellow LED. The Silence switch does not turn off the sounder or Yellow LED during these conditions.

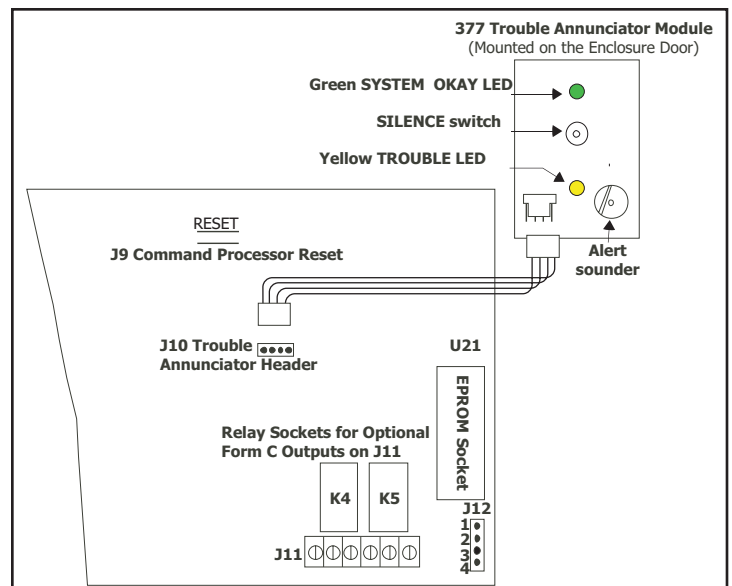

Figure 4: 377 Module Wiring

4.3 Mounting Keypads

DMP keypads have removable covers that allow you to easily mount the base to a wall or other flat surface. After installing the keypad mounting anchors and bringing the keypad wiring from the panel through the wall, mount the base and connect the keypad wire harness leads to the keypad wiring. Next, attach the keypad wire harness connector to the pin connector on the keypad circuit board and install the cover.

For mounting keypads on masonry walls, or for applications where conduit is required, use an appropriate Security Command keypad conduit backbox.

4.4 Wiring Specifications for the Keypad Bus

1. You can install individual keypads on wire runs of up to 500 feet using 22 gauge wire or up to 1,000 feet using 18 gauge wire. To increase the wire length or add additional devices, a power supply is required.
2. Maximum distance for any one keypad bus circuit (length of wire) is 2,500 feet regardless of the gauge of wire. This distance can be in the form of one long wire run or multiple branches with all wiring totaling no more than 2,500 feet.
3. Maximum number of devices per 2,500 feet circuit is 40. (Refer to the Keypad Bus section for the specific number of supervised keypads that are allowed.)
4. Maximum voltage drop between the panel (or auxiliary power supply) and any device is 2.0 VDC. If the voltage at any device is less than the required level, an auxiliary power supply should be added at the end of the circuit.

Refer to the wiring diagram in this guide for additional wiring information. For more information refer to the LX-Bus/Keypad Bus Wiring Application Note (LT-2031) and/or the 710/710F Installation Sheet (LT-0310).

Note: Do not use shielded wire for the keypad bus.

4.5 Terminal Wiring Connections

Caution: Do not use looped wire under terminals. Break wire run to provide supervision of connections. See Figure 5.

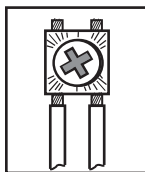

Figure 5: Wiring Connections

Primary Power Supply

5.1 Installing the Transformer



The transformer requires an unswitched 120 VAC 60 Hz electrical outlet with at least 350mA of available current. Never share the transformer output with any other equipment. The 120 VAC circuit is not power limited.

To mount the Model 320 Transformer to a single-gang box adjacent to the XR5 enclosure, follow the steps below. Refer to Figure 6 as needed.

1. Remove the lower knockout from the XR5 enclosure.
2. Attach a single-gang box adjacent to the XR5 enclosure.
3. After the single-gang box is secured, attach the transformer to the junction box, using the bottom box's bottom knockout. The screw on the transformer should extend into the single-gang box.
4. Tighten the screw to secure the transformer to the junction box .
5. An electrician must then connect the black and white leads on the transformer to an unswitched 120 VAC 60 Hz electrical outlet with at least 550mA of available current.
6. Connect the wires from the bottom (the side opposite the attaching screw) two terminals on the transformer to terminals 1 and 2 on the panel. Use no more than 70 ft. of 16-gauge wire or 40 ft. of 18-gauge wire between the transformer and the XR5FC or XR5SL panel.

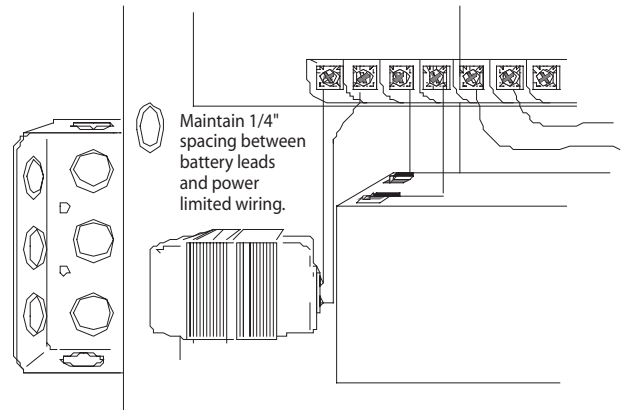

Figure 6: Transformer Installation

5.2 Terminals 1 and 2

AC Transformer Input

The transformer provides up to 500mA of auxiliary current for the XR5FC and XR5SL panels. The total current available is limited by the total battery standby requirements of the installation. See the Power Requirements section for standby battery calculations.

Note: After power is applied to the XR5 panel, any 866 Notification Modules connected to the panel display Bell Trouble for 20 seconds.

DC Power Input to AC Input

When powering the XR5FC/SL panel from the 12 VDC output of an FACP, connect the positive wire to the positive battery terminal of the XR5 and the negative wire to the negative battery terminal of the XR5.

When powering the panel from the DC output of a 24 Volt Fire Alarm Control Panel (FACP), connect the positive wire from the FACP to terminal 1 and the negative wire to terminal 2. In order to power the XR5 from the 12 VDC or 24 VDC of an FACP, the FACP must operate as a grounded control panel. If the FACP is a non-grounded system, it may detect a ground fault when connected to the XR5 panel AC or DC Input terminals. In this case the XR5 should be powered from a separate 320 wire-in transformer and not from the FACP.



Do not use battery backup with 12 or 24 VDC input: Do not connect any batteries to the XR5FC or XR5SL panels when using the 12 or 24 VDC output from a FACP. The XR5FC and XR5SL panels use the backup battery capability of the FACP for their standby requirements.

When powering the XR5FC or XR5SL panel from the 24 VDC output of a FACP, the following features are disabled:

- Bell Output on the XR5FC
- AC test (XR5FC and XR5SL)
- Battery test (XR5FC and XR5SL)



Always ground the panel before applying power to any devices: The XR5FC and XR5SL panels must be properly grounded before connecting any devices or applying power to the panels. Proper grounding protects against Electrostatic Discharge (ESD) that can damage system components. See the Earth ground section.

Secondary Power Supply

6.1 Battery Terminals 3 and 4

Connect the black battery lead to terminal 4 on the panel and then to the negative terminal of the battery. The negative terminal connects to the enclosure ground internally through the XR5FC and XR5SL panel circuit board. Connect the red battery lead to terminal 3 on the panel and then to the positive terminal of the battery. Observe polarity when connecting the battery.

The XR5FC and XR5SL panels are capable of recharging two 7.7 Ah batteries (15.4 Amp/hours) within 24 hours.

Do not use battery backup with 24 VDC input: Do not connect batteries to the XR5FC and XR5SL panels when powering the panels with 20 to 28.2 VDC voltage from a Fire Alarm Control Panel (FACP). The XR5FC and XR5SL panels use the backup battery capability of the FACP for their standby requirements.



Use sealed lead-acid batteries only: Use the DMP Model 367, 12 VDC 7.7 Ah or Model 369 7.0 Ah sealed lead-acid rechargeable battery. Batteries supplied by DMP have been tested to ensure proper charging with DMP products.

DO NOT USE GEL CELL BATTERIES WITH THE XR5FC AND XR5SL.

6.2 Earth Ground (GND)

Terminal 4 of the XR5FC and XR5SL panels must be connected to earth ground using 14 gauge or larger wire to provide proper transient suppression. DMP recommends connecting to a metal cold water pipe or ground rod only. Do not connect to electrical conduit or a telephone company ground.

6.3 Battery Replacement Period

DMP recommends replacing the battery every 3 to 5 years under normal use.

6.4 Discharge/Recharge

The battery charging circuit on the XR5FC and XR5SL panels float charge at 13.9 VDC at a maximum current of 1.2 Amps using the Model 320 Transformer. The total current available is reduced by the combined auxiliary current draw from terminals 6, 7, 15, 17, 19, and 21. The various battery voltage levels are listed below:

Battery Trouble: Below 11.9 VDC

Battery Restored: Above 12.6 VDC

6.5 Battery Supervision

The XR5FC and XR5SL panels load test the battery once every three minutes when AC power is present on terminal 1 and 2. The test lasts for five seconds. If, during the test, the battery voltage falls below 11.9 VDC a low battery is indicated. The test is then repeated every two minutes until the battery charges above 12.6 VDC, the battery restored voltage.

If the low battery does not recharge and is replaced with a fully charged battery, the charged battery will not be detected until the next two minute test is done.

If AC power fails during normal system operation, a low battery is indicated any time the battery voltage falls below 11.9 VDC.

6.6 XR5FC and XR5SL Power Requirements

During AC power failure, the XR5FC and XR5SL panels, and all auxiliary devices connected to the panels, draw their power from the battery. All devices must be taken into consideration when calculating the battery standby capacity. Below is a list of the power requirements of the XR5FC and XR5SL panels. Add the additional current draw of DMP keypads, smoke detectors, and any other auxiliary devices used in the system for the total current required.

6.7 XR5FC and XR5SL Standby Battery Calculations

Standby Battery Power Calculations	Standby Current	Alarm Current
XR5FC/XR5SL Panel	Qty <u> 1 </u> x 50mA <u> </u> mA	Qty <u> 1 </u> x 50mA <u> </u> mA
Relay Outputs 1-2 (ON)	Qty <u> </u> x 30mA <u> </u>	Qty <u> </u> x 30mA <u> </u>
Active Zone 1	3.3mA <u> </u>	3.3mA <u> </u>
Active Zones 2-5	Qty <u> </u> x 4mA <u> </u>	Qty <u> </u> x 4mA <u> </u>
521B/BXT Smoke Detectors	Qty <u> </u> x 0.070mA <u> </u>	Qty <u> </u> x 0.070mA <u> </u>
SLR-835B Smoke Detectors	Qty <u> </u> x 0.070mA <u> </u>	Qty <u> </u> x 0.070mA <u> </u>
Other 2-Wire Smoke Detectors	Qty <u> </u> x 0.1mA <u> </u>	Qty <u> </u> x 0.1mA <u> </u>
Bell Output (600mA Max.)	<u> </u>	<u> </u> mA
377 Trouble Annunciator Module	17mA <u> </u>	17mA <u> </u>
630F Remote Fire Command Center	Qty <u> </u> x 63mA <u> </u>	Qty <u> </u> x 92mA <u> </u>
692F Fire Security Command Keypad	Qty <u> </u> x 30mA <u> </u>	Qty <u> </u> x 70mA <u> </u>
714 Zone Expansion Module	Qty <u> </u> x 7mA <u> </u>	Qty <u> </u> x 7mA <u> </u>
Active Zones (EOL Installed)	Qty <u> </u> x 1.6mA <u> </u>	Qty <u> </u> x *2mA <u> </u>
715 Zone Expansion Module	Qty <u> </u> x 7mA <u> </u>	Qty <u> </u> x 7mA <u> </u>
Active Zones (EOL Installed)	Qty <u> </u> x 4mA <u> </u>	Qty <u> </u> x *30mA <u> </u>
Smoke Alarms	Qty <u> </u> x .1 mA <u> </u>	Qty <u> </u> x .1mA <u> </u>
865 Style W or X Notification Module	Qty <u> </u> x 26mA <u> </u>	Qty <u> </u> x 85mA <u> </u>
866 Style W Notification Module	Qty <u> </u> x 45mA <u> </u>	Qty <u> </u> x 76mA <u> </u>
Aux. Powered Devices on Terminals 7 and 6 Other than Keypads	<u> </u> mA	<u> </u> mA
Total Standby <u> </u> mA		Total Alarm <u> </u> mA
Total Standby <u> </u> mA x number of Standby Hours needed <u> </u> =		<u> </u> mA-hours
Total Alarm <u> </u> mA		<u> </u> mA-hours
+		<u> </u> mA-hours
*Based on 10% of active zones in alarm		Total X 0.0001
		= <u> </u> Amp-hrs Required

Bell Output

7.1 Terminal 5 (XR5FC Only)

Terminal 5 supplies 12 VDC Bell Output to power alarm bells or horns. The output is rated for a maximum of 1.5 Amps. This output can be steady or temporal depending upon the Bell Action specified in Output Options programming. Terminal 10 is the ground reference for terminal 5. See the Notification Appliance section for a list of approved notification appliances and the Wiring Diagrams for connections

4-Wire Smoke Detector Power

8.1 Terminal 6 (XR5FC Only)

Terminal 6 provides up to 100mA at 12 VDC to power 4-wire smoke detectors or other auxiliary powered devices. This output can be turned off by the user for 5 seconds using the Sensor Reset User Menu option. Terminal 10 is the ground reference for terminal 6.

Keypad Bus

9.1 Description

Terminals 7, 8, 9, and 10 of the XR5FC and XR5SL panels provide a Class B, Style 3.5 keypad bus to connect an unlimited number of 692F LED keypads, two 630F keypads, and other auxiliary devices. In addition, to keypads, connect a 714 or 715 zone expansion module to the Keypad Bus.

9.2 Terminal 7 - RED

Terminal 7 provides 12 VDC regulated keypad power for DMP keypads. You can also connect 12 VDC auxiliary devices to terminal 7. The ground reference for terminal 7 is terminal 10. The maximum output is rated at 500mA on the XR5FC and XR5SL panels. All auxiliary devices totalled together must not exceed the panel's maximum current rating. See Power Supply in the Compliance section for maximum current in a fire listed application.

9.3 Terminal 8 - YELLOW

Data receive from devices.

9.4 Terminal 9 - GREEN

Data transmit to devices.

9.5 Terminal 10 - BLACK

Terminal 10 is the ground reference for keypads and any auxiliary devices powered by terminal 7.

Note: Do not use shielded wire when wiring keypads or other devices.

Class A (Style D) Fire Zone

10.1 Description

Terminals 11 to 14 are the panel's Class A (Style D) fire zone. This zone is suitable for connecting waterflow devices, heat detectors, and other non-powered fire devices. For programming purposes, this is zone number 1. The zone is rated for 1.66mA at 5.0 VDC.

The zone configuration on terminals 11 to 14 are described below.

Terminal	Function	Terminal	Function
11	Zone 1 voltage sensing	12	Negative for terminal 11
13	Zone 1 voltage sensing	14	Negative for terminal 13

The voltage sensing terminal measures the voltage across the circuit and the zone's negative terminal. Dry contact sensing devices can be used only in parallel (normally-open) with zone 1. There are no End-of-Line resistors on a Class A (Style D) zone. The maximum line impedance is 100 Ohms.

Class B (Style A) Fire Zones

11.1 Description

Terminals 15 to 22 are the Class B (Style A) fire zones on the XR5FC and XR5SL panels. These zones are suitable for connecting powered or non-powered fire devices. For programming purposes, these zones are designated 2 to 5. The maximum line impedance is 100 Ohms. The zone configurations on terminals 15 to 22 are described below:

Terminal	Function	Terminal	Function
15	Zone 2 voltage sensing	16	Zone 2 negative
17	Zone 3 voltage sensing	18	Zone 3 negative
19	Zone 4 voltage sensing	20	Zone 4 negative
21	Zone 5 voltage sensing	22	Zone 5 negative

11.2 Operational Parameters

The Class B (Style A) zones on the XR5FC and XR5SL panels can detect three conditions: open, normal, and short. Each zone terminates with a Model 309, 3.3k Ohm EOL resistor (provided with the panel) and is rated for 53mA at 12 VDC.

The compatibility identifier for use with 2-wire smoke detectors is: A.

11.3 Zone Response Time

A condition must be present on the zone for at least 500 milliseconds before it is detected by XR5FC and XR5SL panels. Only use detection devices that are rated for use with this delay.

11.4 Compatible 2-Wire Smoke Detectors

The table below lists detectors meeting the compatibility requirements for use with the Class B (Style A) zones on the XR5FC and XR5SL fire panels. Do not mix detectors from different manufacturers on the same zone.

Manufacturer	Model	Detector ID	Base	Base ID	# of Detectors
Detection Systems	DS250	B	MB2W	A	10
Detection Systems	DS250TH, DS250HD	B	MB2W, MB2WL	A	10
Detection Systems	DS282, DS282TH	B			10
Hochiki	SLK-12	HD-4	HSB-12-1, HSB-12-1N	HB-80	20
DMP/Hochiki	SLK-835, SLK-835H	HD-5	HSB-200, HSB-200N	HB-55	7
DMP/Hochiki	SLR-835	HD-3	NS6-100	HB-55	7
DMP/Hochiki	SLR-835B	HD-6			7
Sentrol/ESL	429AT, 521B, 521BXT	S09A			12
System Sensor	1100, 1400	STD			10
System Sensor	1151	STD	B110LP		10
System Sensor	1451, 2451TH	STD	B401, B401B		10
System Sensor	1451DH	STD	DH400		10
System Sensor	2100, 2100T	STD			10
System Sensor	2400, 2400AT, 2400AIT, 2400TH	STD			10
System Sensor	2451	STD	B401, B401B, DH400		10

Form C Relay Outputs

12.1 Description

The XR5FC and XR5SL panels can provide two programmable auxiliary Form C (SPDT) relays when equipped with DMP Model 305 Plug-in Relays in sockets OUTPUT 1 and OUTPUT 2. Each relay is rated for 1 Amp at 30 VDC (allows .35 power factor).

Each output provides one Common, one Normally Open, and one Normally Closed terminal. Field wiring for the Form C relays connects to the 6-position terminal strip on the lower right corner of the XR5FC and XR5SL boards.

The Form C relays can be operated by any of the functions listed below:

- 1) Activation by a zone condition
- 2) Communication Failure
- 3) Fire alarm or Fire trouble

Annunciator Outputs

13.1 Description

The XR5FC and XR5SL panels provide four programmable open collector annunciator outputs that can be programmed to indicate the activity of the panel zones or conditions occurring on the system. Open collector outputs do not provide a voltage but instead switch to ground voltage from another source. Each annunciator output is rated for 50mA at 30 VDC resistive.

Form C and Annunciator outputs operate together: The Form C outputs 1 and 2 are internally connected to the Annunciator outputs 1 and 2. Any options assigned to Output 1 or 2 in the panel's Output Options programming applies to both outputs. While the Form C outputs each require a Model 305 Plug-in Relay, the annunciator outputs work without the relays.

The Annunciator outputs can respond to any of the conditions listed below:

- 1) Activation by zone condition
- 2) Communication failure
- 3) Fire Alarm, Fire Trouble, or Supervisory

13.2 Harness Wiring

The Annunciator outputs are accessible by installing the DMP 300 Harness on the 4-pin header labeled J12. The output locations are shown below:

Output	Color	Wire
1	Red	1
2	Yellow	2
3	Green	3
4	Black	4

Devices connected to the outputs must be located within the same room as the XR5FC and XR5SL panels.

Telephone RJ Connector

14.1 Description

Connect the panel to the public telephone network by installing DMP 356 RJ Cables between the panel's J4 (MAIN) and J5 (BACKUP) connectors, and the RJ31X or RJ38X phone jacks on the 356 cable. The maximum line impedance is 100 Ohms.

14.2 FCC Registration

The XR5FC and XR5SL panels comply with FCC part 68 and are registered with the FCC.

Registration number: CCKUSA - 18660 - AL - R

Ringer Equivalence: 1.1B

14.3 Notification

Registered terminal equipment must not be repaired by the user. In case of trouble, the device must be immediately unplugged from the telephone jack. The factory warranty provides for repairs. Registered terminal equipment may not be used on party lines or in connection with coin telephones. Notification must be given to the telephone company of:

- a. The particular line(s) the service is connected to
- b. The FCC registration number
- c. The ringer equivalence
- d. The make, model, and serial number of the device

Reset Jumper J9

15.1 Description

There is a reset jumper located at the top right of the panel circuit board labeled RESET. Momentarily shorting the metal wires of the jumper with a screwdriver resets the microprocessor of the XR5FC and XR5SL panels to enter the internal Programmer.

Reset the panel while the system is operational (for example, during a service call) without powering down the system.

After resetting the panel for programming, begin within 30 minutes. If longer than 30 minutes, reset the panel again.

Silence/Reset Button

16.1 Silence/Reset Button

The XR5FC and XR5SL panels each contain a mechanical push button located on the top center of the printed circuit board that allows authorized users to silence alarm bells or sirens and reset latched detection devices.

After pressing the button, the panel silences the Bell output (XR5FC terminal 5) and momentarily drops power to the auxiliary output (XR5FC terminal 6), the 377 Trouble Annunciator Module, and zones 2 to 5 (both panels). Additionally, any Fire or Supervisory event displays at the keypads are also cleared. A 2-pin reset header (J13) is also provided for use with keyswitches.

16.2 Bell Circuit Monitor

The XR5FC panel contains a bell monitor input (J14) that can be connected to the trouble contacts of the Model 865 or 866 Notification Circuit Module. When the 2-pin header is shorted via the notification module, the Bell Circuit Monitor is in a restored condition. When the trouble contacts open, a bell circuit trouble is indicated. The XR5FC is shipped from the factory with a shorting clip on the 2-pin header to indicate a restored condition. The DMP Model 306 harness is used to connect the J14 Bell Circuit Monitor to the trouble contacts of the 865 or 866 Notification Circuit Module.

Dual Phone Line Connectors

17.1 Description

The XR5FC and XR5SL panels contain built-in dual phone line capability that allows the panel to monitor two phone lines, indicate a phone line failure, and switch to the alternate phone line to communicate alarm and system reports to a central station.

Before sending a report, the panel verifies whether the main phone line is working. If not, the panel sends the report over the backup phone line. An integrated phone line monitor circuit continually tests the phone lines and indicates a trouble condition on the line after 90 seconds. If the phone line restores and is good for 90 seconds, the panel ends the phone line trouble indication.

The maximum line impedance is 100 Ohms.

Listed Compliance Specifications

18.1 Introduction

For applications that must conform to a local authorities installation standard or a National Recognized Testing Laboratory certificated system, please see the following sections.

18.2 NFPA

This equipment should be installed in accordance with the National Fire Alarm Code, ANSI/NFPA 72, (National Fire Protection Association, Batterymarch Park, Quincy, MA 02269). Printed information describing proper installation, operation, testing, maintenance, evacuation planning, and repair service is to be provided with this equipment. Warning: Owner's instruction notice shall not be removed by anyone except occupant.

Universal Fire Alarm Specifications

19.1 Introduction

The programming and installation specifications contained in this section must be completed when installing the XR5FC and XR5SL panels in accordance with any of the ANSI/UL or NFPA fire standards. Additional specifications may be required by a particular standard. See the XR5FC and XR5SL Programming Guide (LT-0312).

19.2 Wiring

All wiring must be in accordance with NEC, ANSI/NFPA 70.

19.3 Police Station Phone Number

The digital dialer telephone number programmed for communication must not be a police station phone number, unless that phone number is specifically provided for that purpose.

19.4 System maintenance

Proper installation and regular maintenance by the installing alarm company and frequent testing by the end user is essential to ensure continuous satisfactory operation of any alarm system. Offering a maintenance program and acquainting the user with the correct procedure for use and testing of the system is also the responsibility of the installing alarm company.

19.5 Audible alarm (XR5FC only)

Fire Type zones should be programmed to activate an audible alarm. The Bell Action for Fire Type zones should not be programmed as "N".

19.6 Listed Receivers

Operation has been verified with the SCS-1R, Sur-Gard SG-HLR2-DG, FBII CP220PB, Osborne-Hoffman Quick-Alert, and Radionics D6500 receivers.

Control Units for Fire-Protective Signaling Systems ANSI/UL 864, NFPA 72

20.1 Power Supply

For listed installations, the total current combined from Auxiliary and Bell Power cannot exceed:
1.0 Amps with a 40 VA transformer; .4 Amp Max for Auxiliary Power and .6 Amp Max for Bell

20.2 Power Fail delay

The Power Fail Delay option must be set to a maximum of 3 hours .

20.3 Central Station Signaling Systems

Two phone lines must be used. The two phone lines cannot be ground start or party lines.

Two different phone numbers must be programmed for digital communication.

20.4 Local Protective Signaling Systems

The DMP Model 865 or 866 Notification Circuit Module must be used on the bell circuit for detection of shorts and grounds.

20.5 Remote Station Protective Signaling Systems

60 hours of standby battery must be provided. Up to two 12 VDC, 7.0 Ah batteries may be used. See standby battery calculations. Two Radionics Model D127 Reversing Relay Modules may be used to provide two reversing polarity telephone connections instead of dual phone lines. See the D127 Installation Instruction sheet for wiring details.

20.6 Remote Annunciators

At least one Model 630F or 692F Remote Annunciator must be used on the system. When using a 692F keypad, install one the panel door as described in the 692F installation guide (LT-0317).

When using a 630F keypad, install the keypad using conduit within 20 feet of the panel.

20.7 Notification Appliances

The following table indicates approved 12 VDC notification appliances.

Wheelock Model No.	Description	No. of Appliances
MT-12/24	Multi-tone Horn	5
MB-G6-12	Bell, 6 inch	11
MB-G10-12	Bell, 10 inch	11
RSS-121575W-F	Strobe, 15/75 candela	3
RSSP-121575W-F	Strobe, w/retrofit plate	3
NS-121575W-F	Horn Strobe, 15/75 candela	3
SM-12/24-R	Sync Module, Single circuit,	
DSM-12/24-R	Sync Module, Dual circuit	

20.8 Cross Zoning

When using cross zoning, there must be a minimum of two detectors installed in each protected space and the detector installation spacing must be 0.7 times the linear spacing in accordance with National Fire Alarm Code, NFPA 72.

20.9 Ground Fault

For supervised circuits, ground fault is detected at 0 (zero) Ohms.

California State Fire Marshal Specifications

21.1 Bell Output Definition

The bell output of the Model XR5FC must be programmed to operate Temporal for fire alarms.

Wiring Diagrams

22.1 866 with NAC Extender

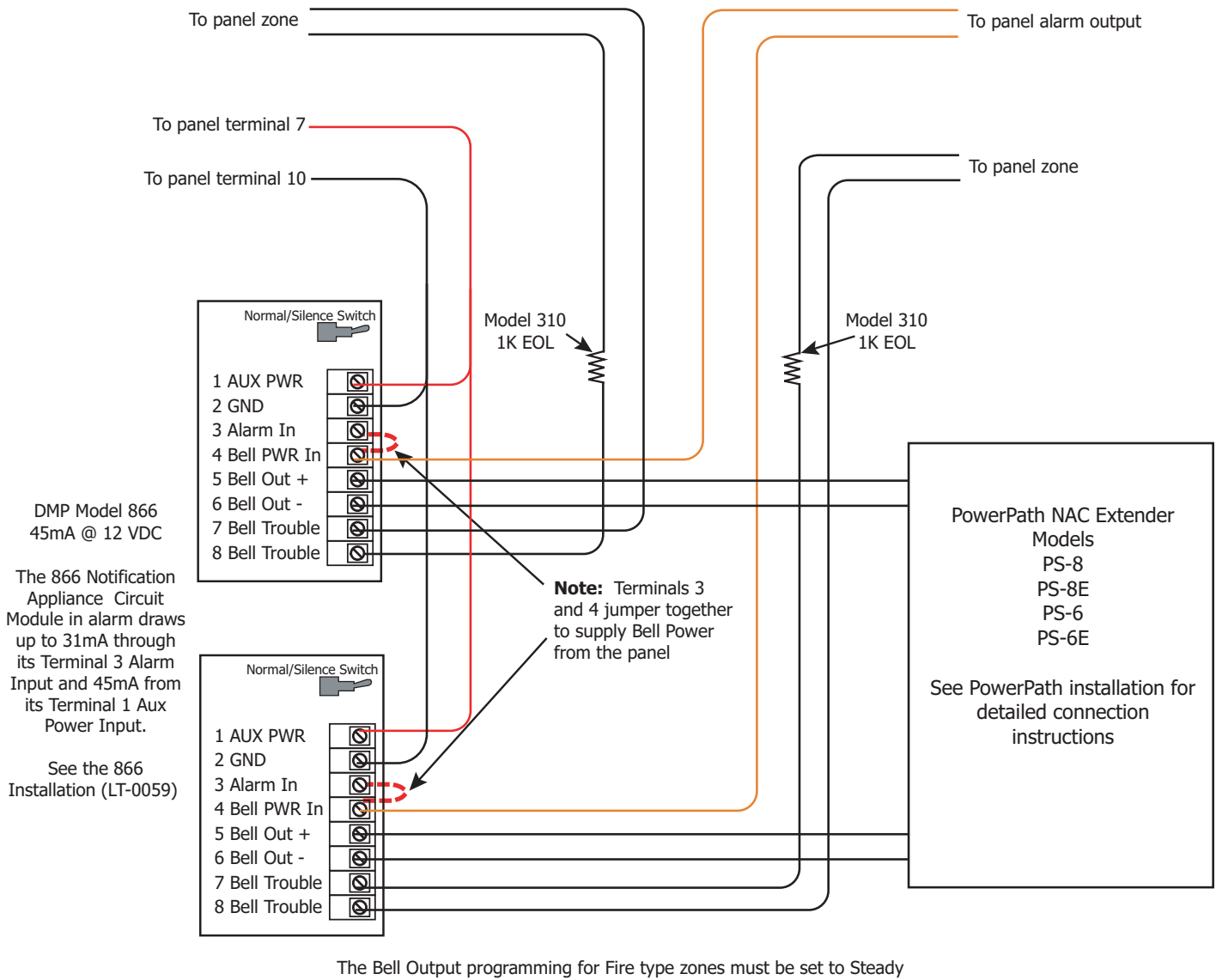

22.2 866 Class B Style W using Single Notification Appliance

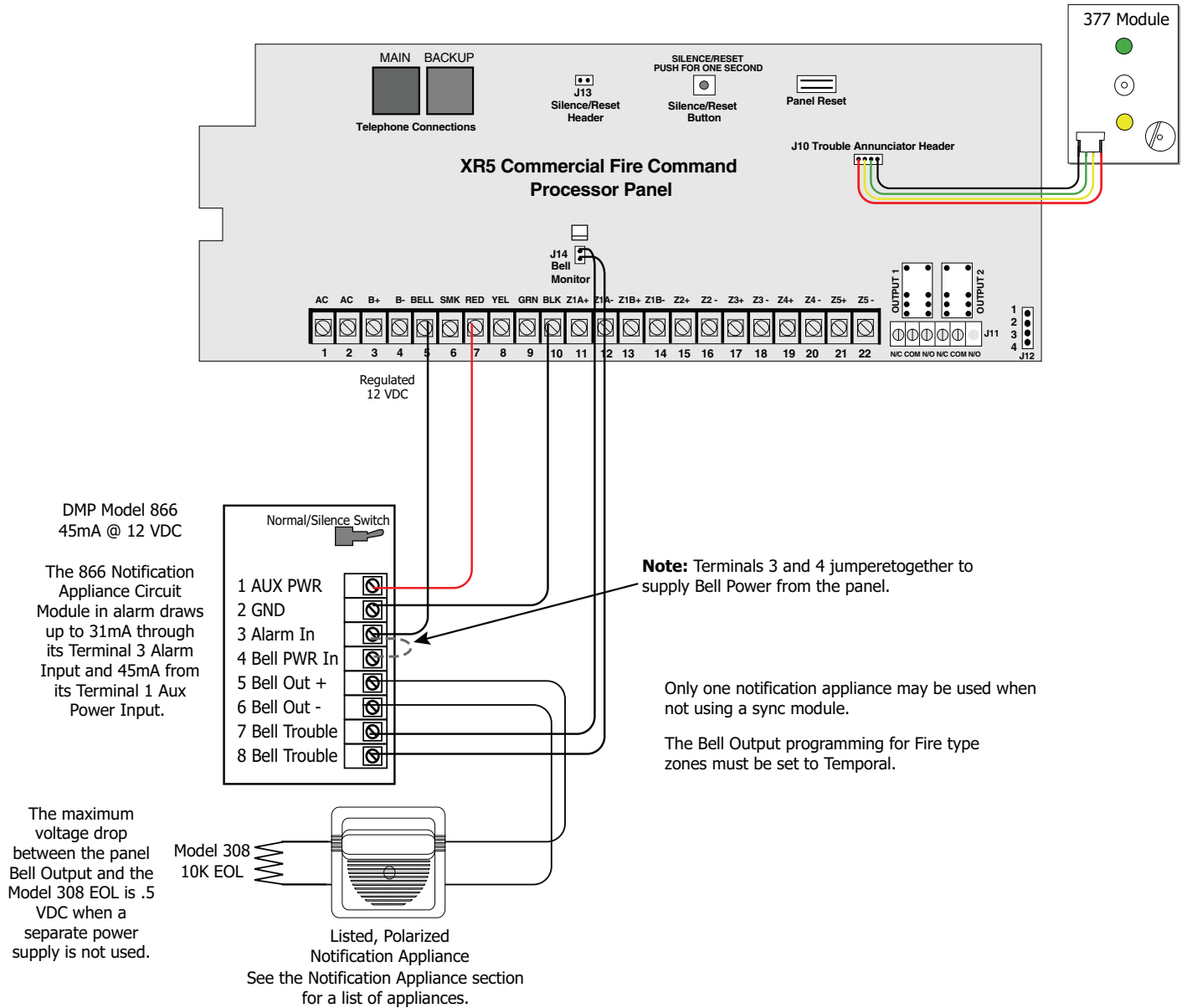

22.3 866 Class B Style W using Multiple Notification Appliances

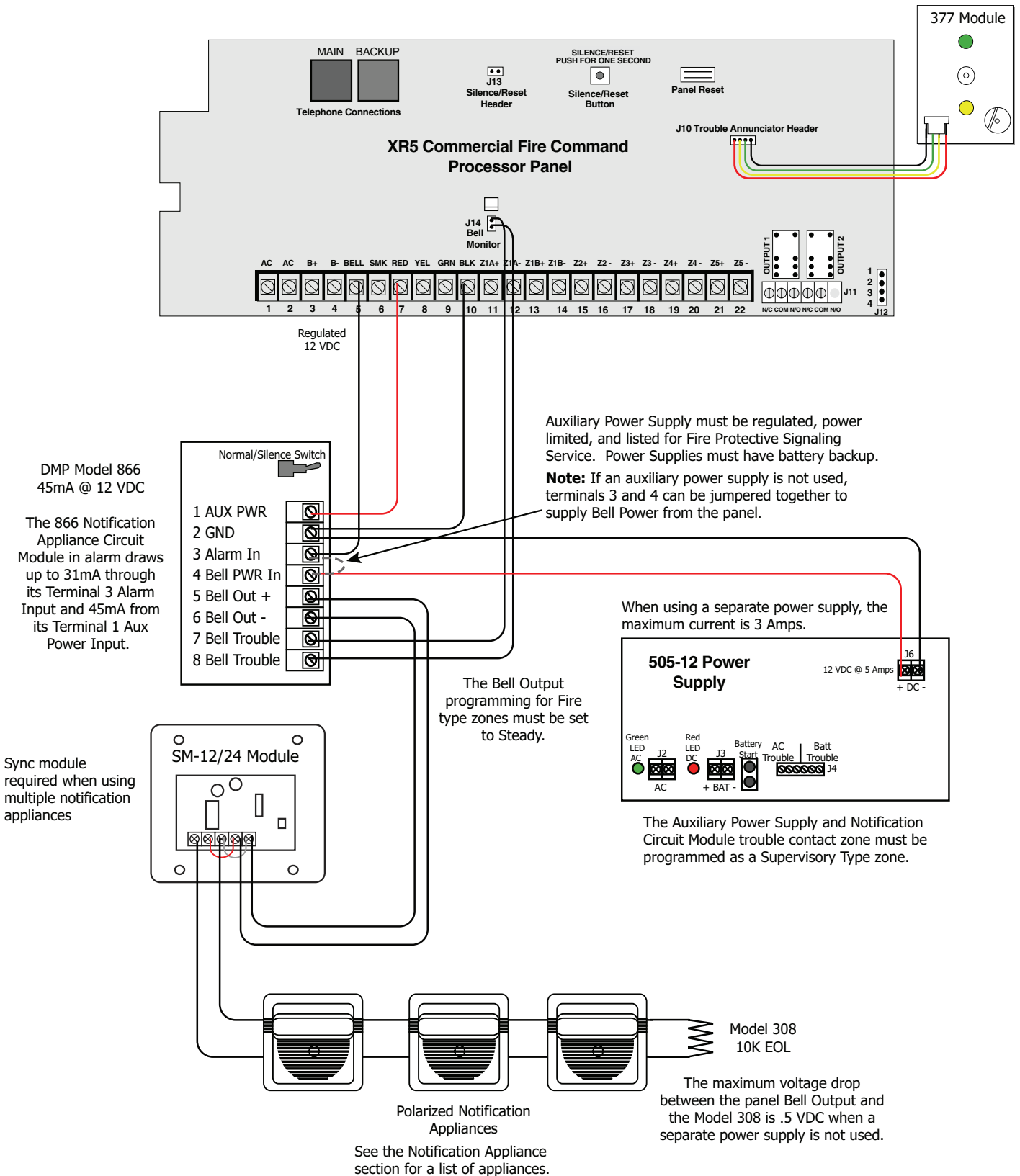

22.4 866 Class B Style W Multiple Notification Appliance Circuits

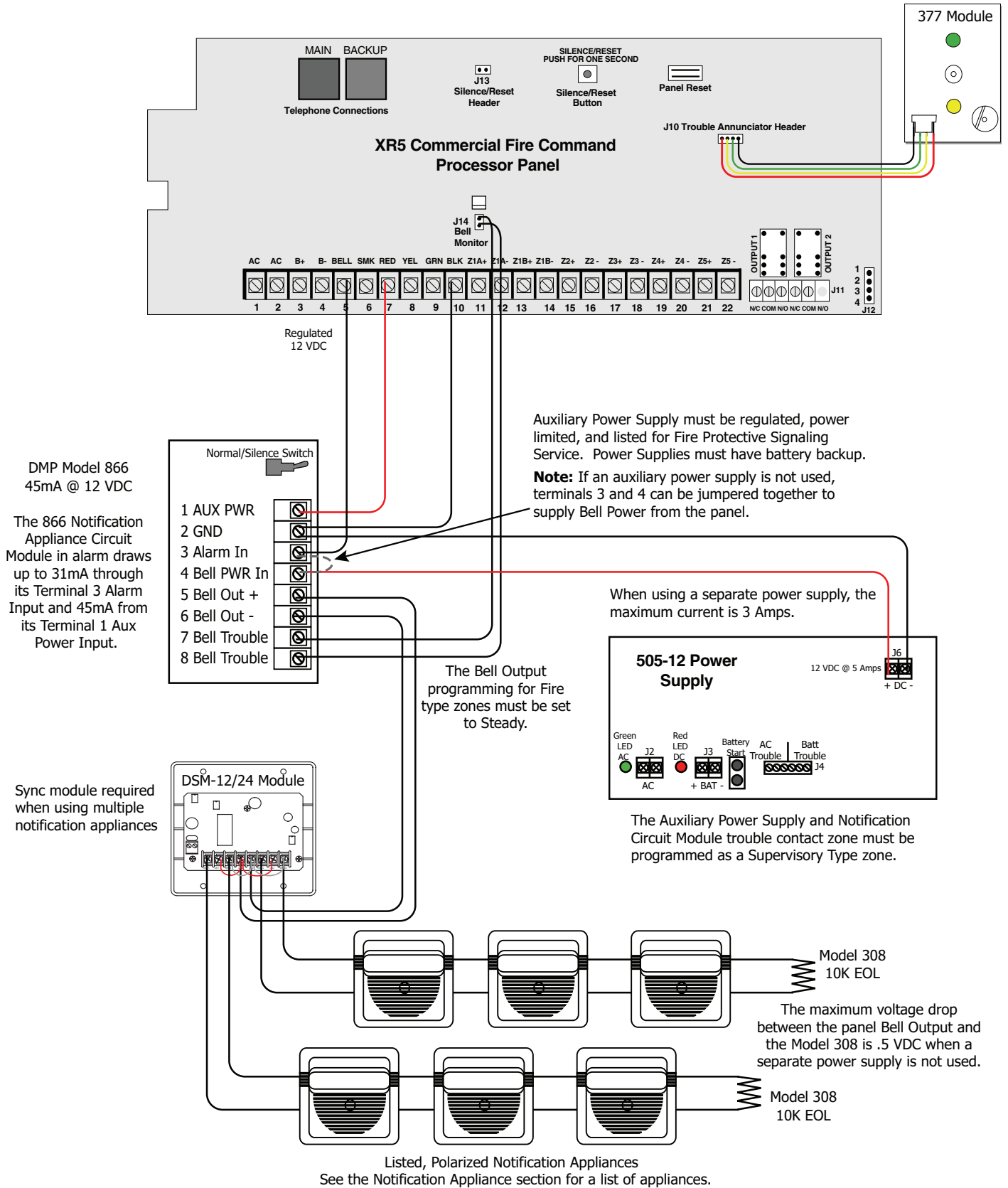

22.5 865 Class B Style W using Single Notification Appliance

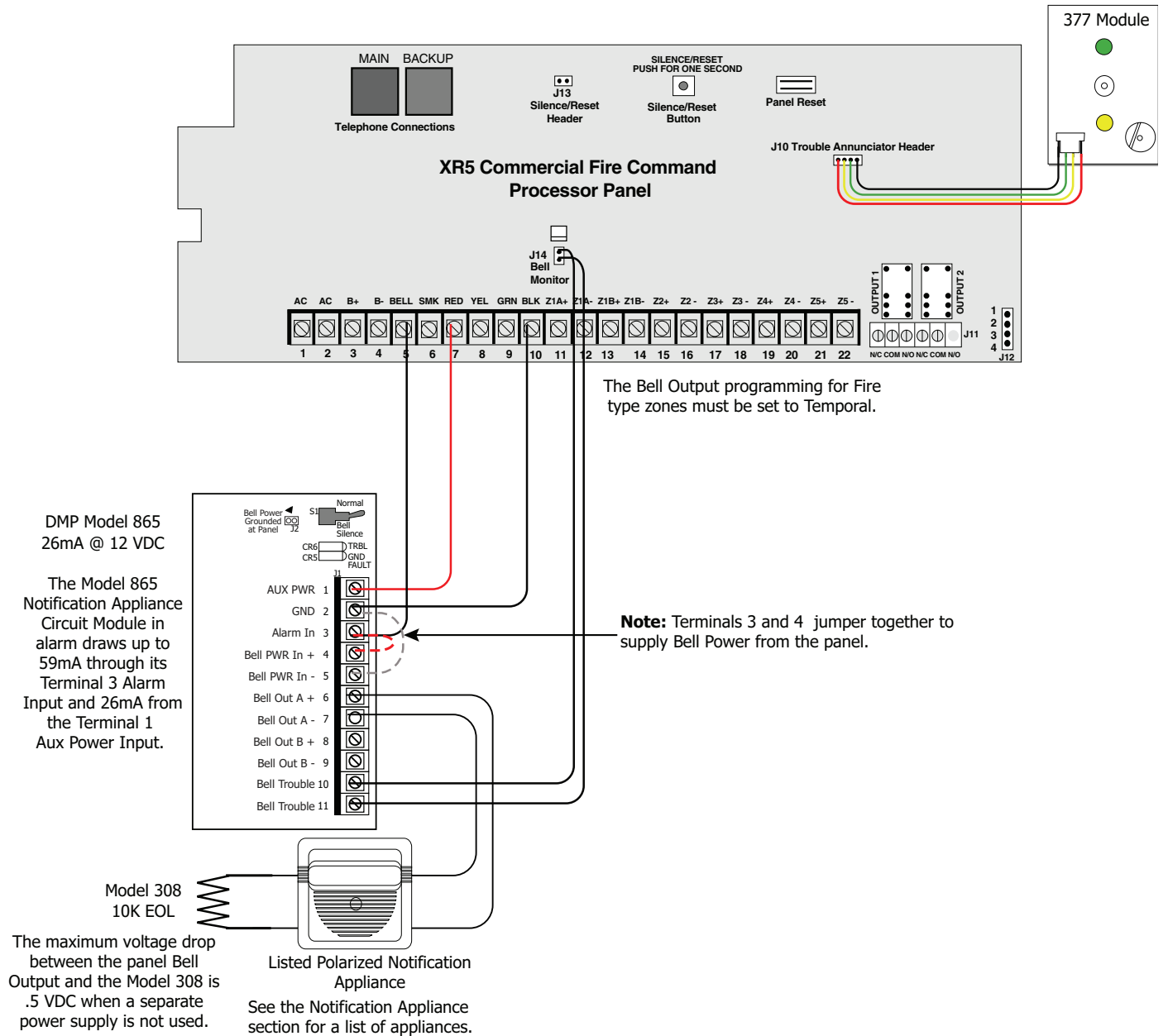

22.6 865 Class B Style W Multiple Notification Appliances

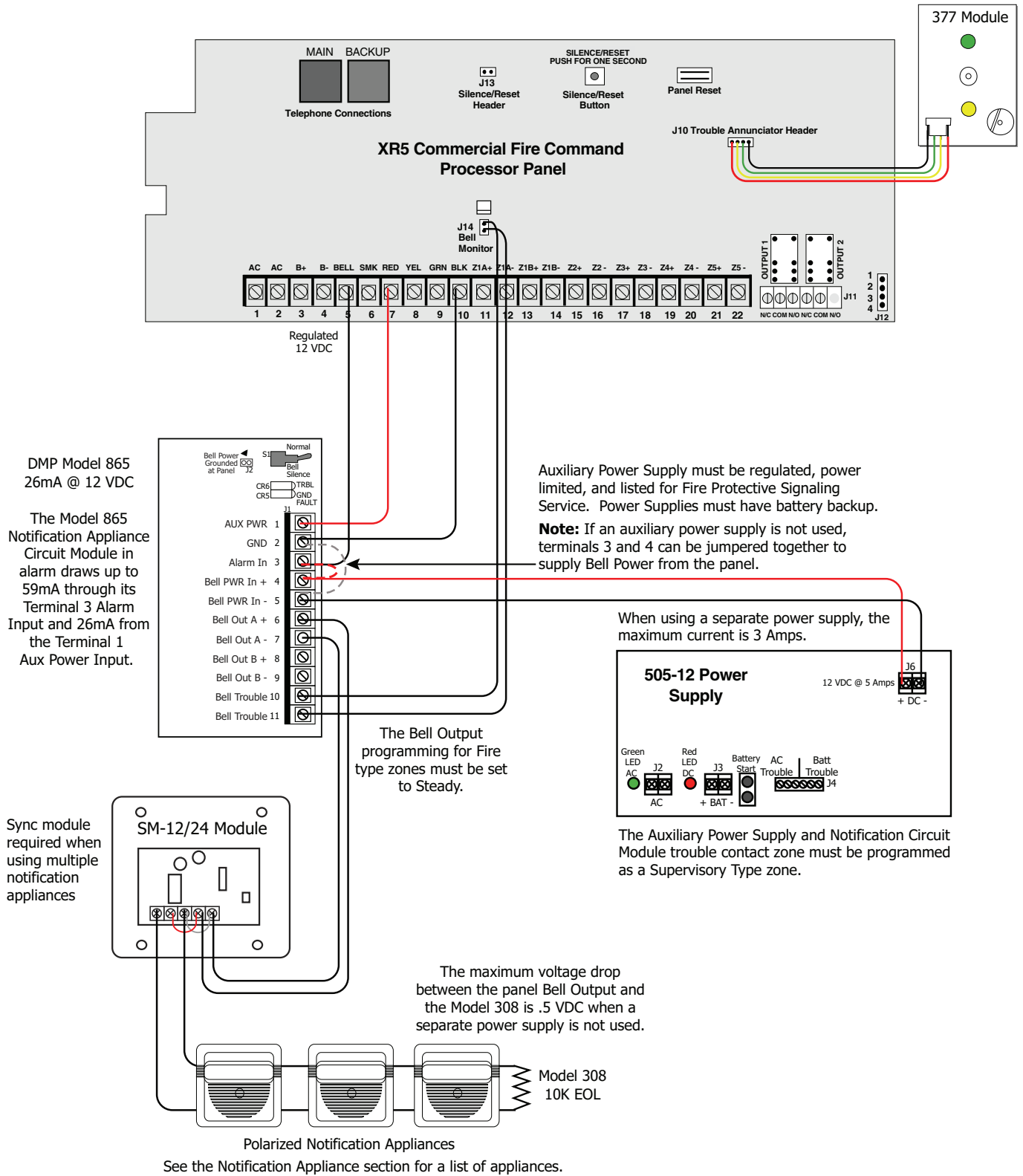

22.7 865 Class B Style W Multiple Notification Appliance Circuits

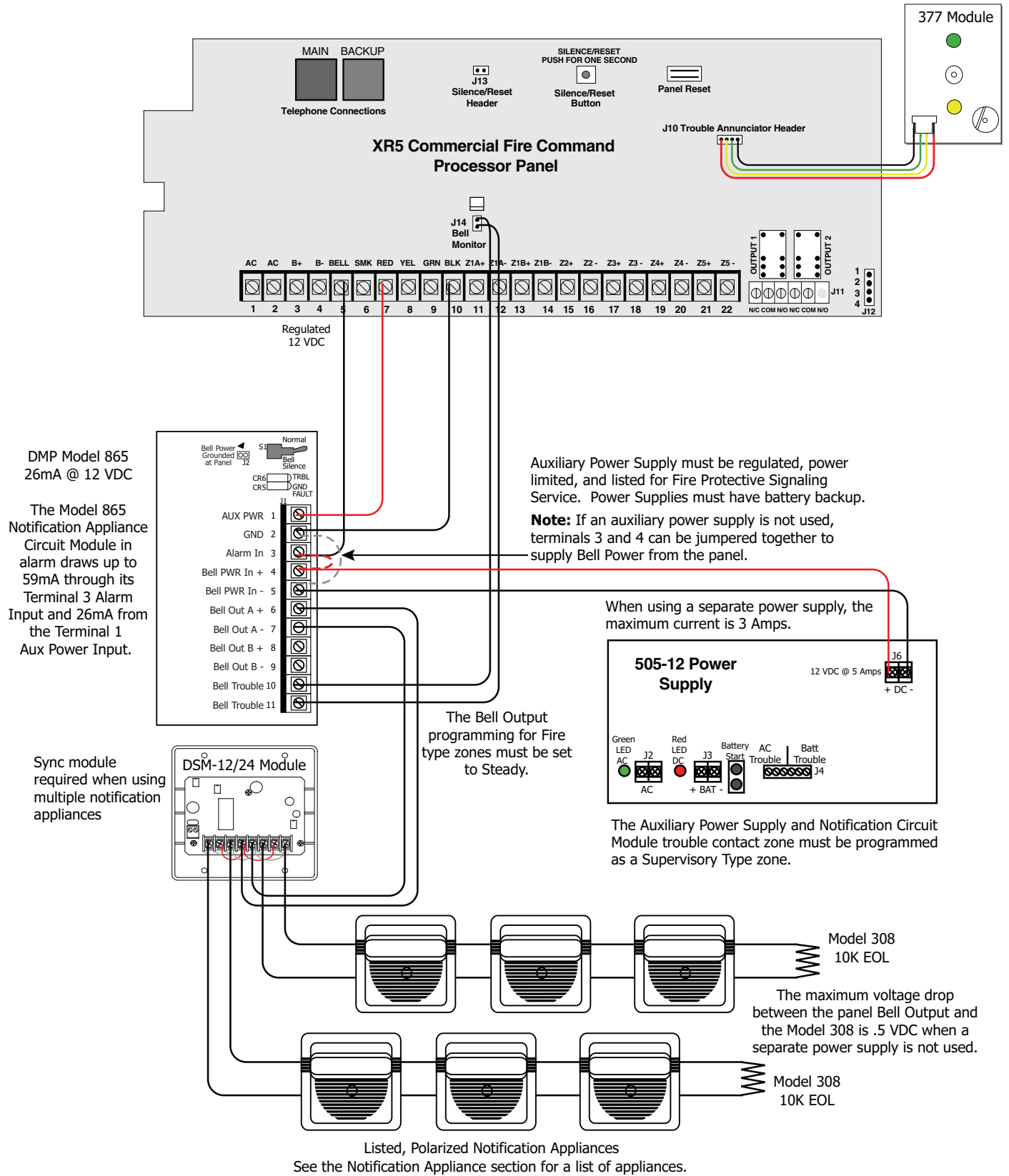

22.8 865 Class A Style X using Single Notification Appliance

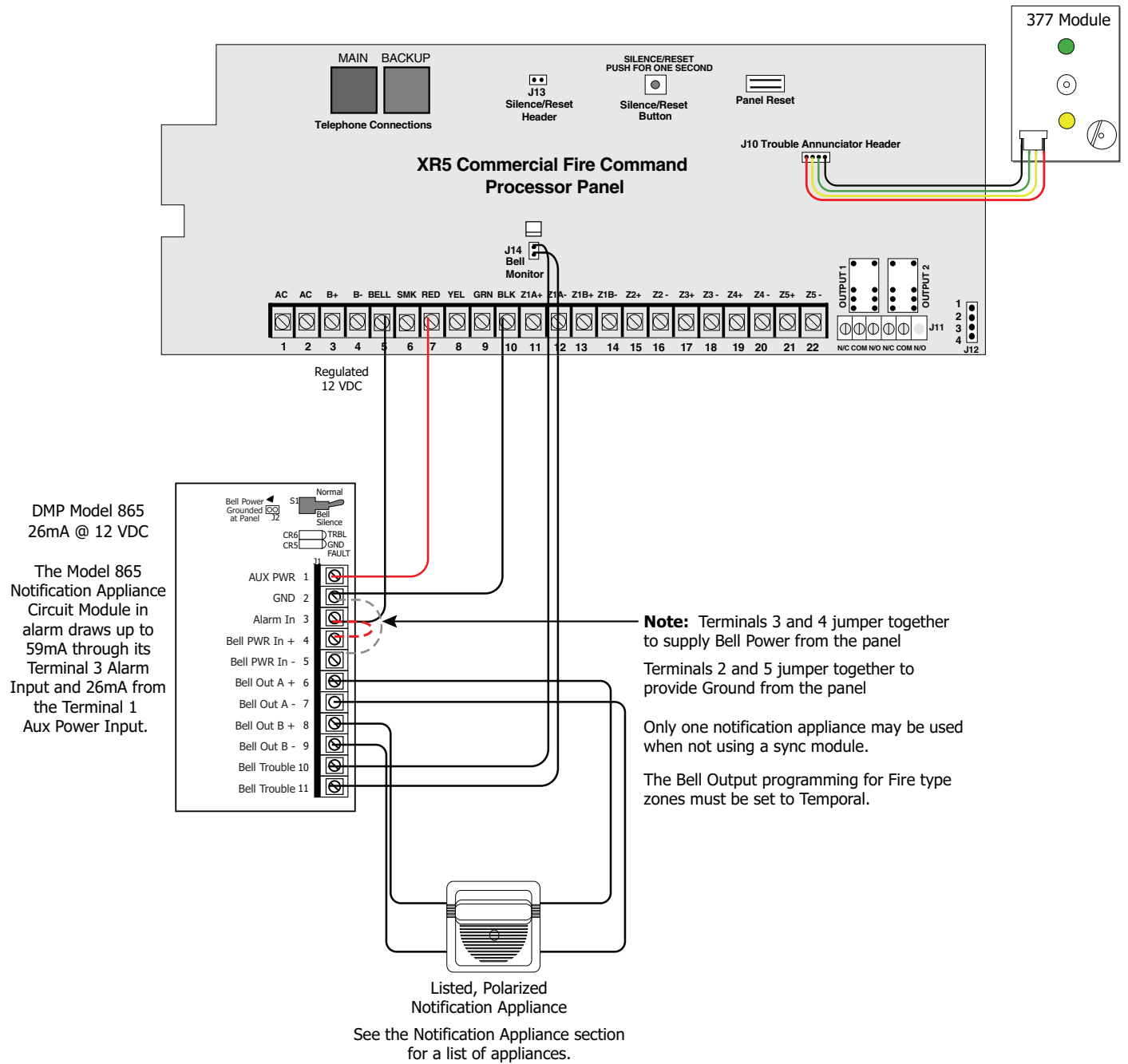

22.9 Remote Station Reversing Relay Connection

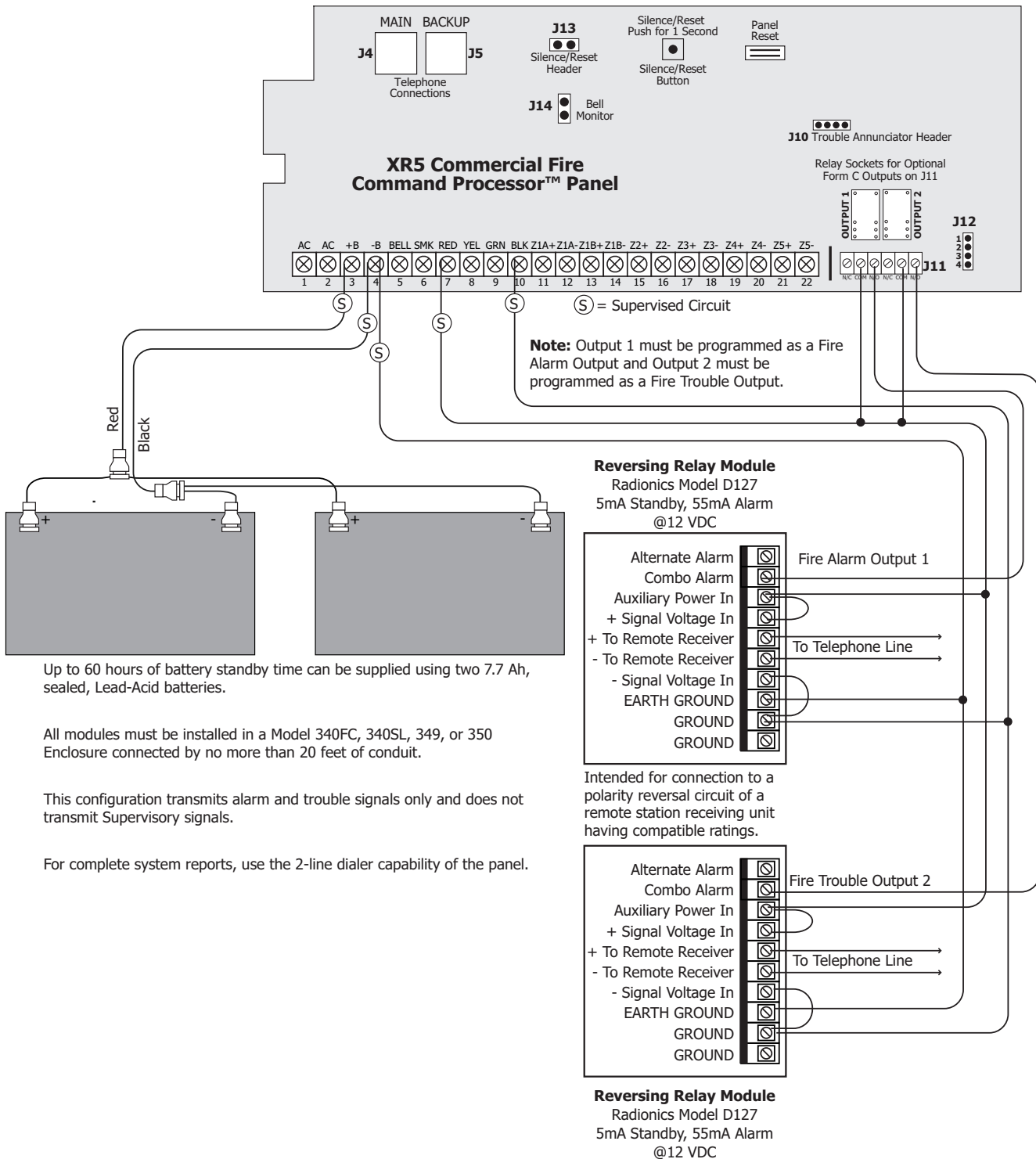

22.10 Supervised Remote Relay

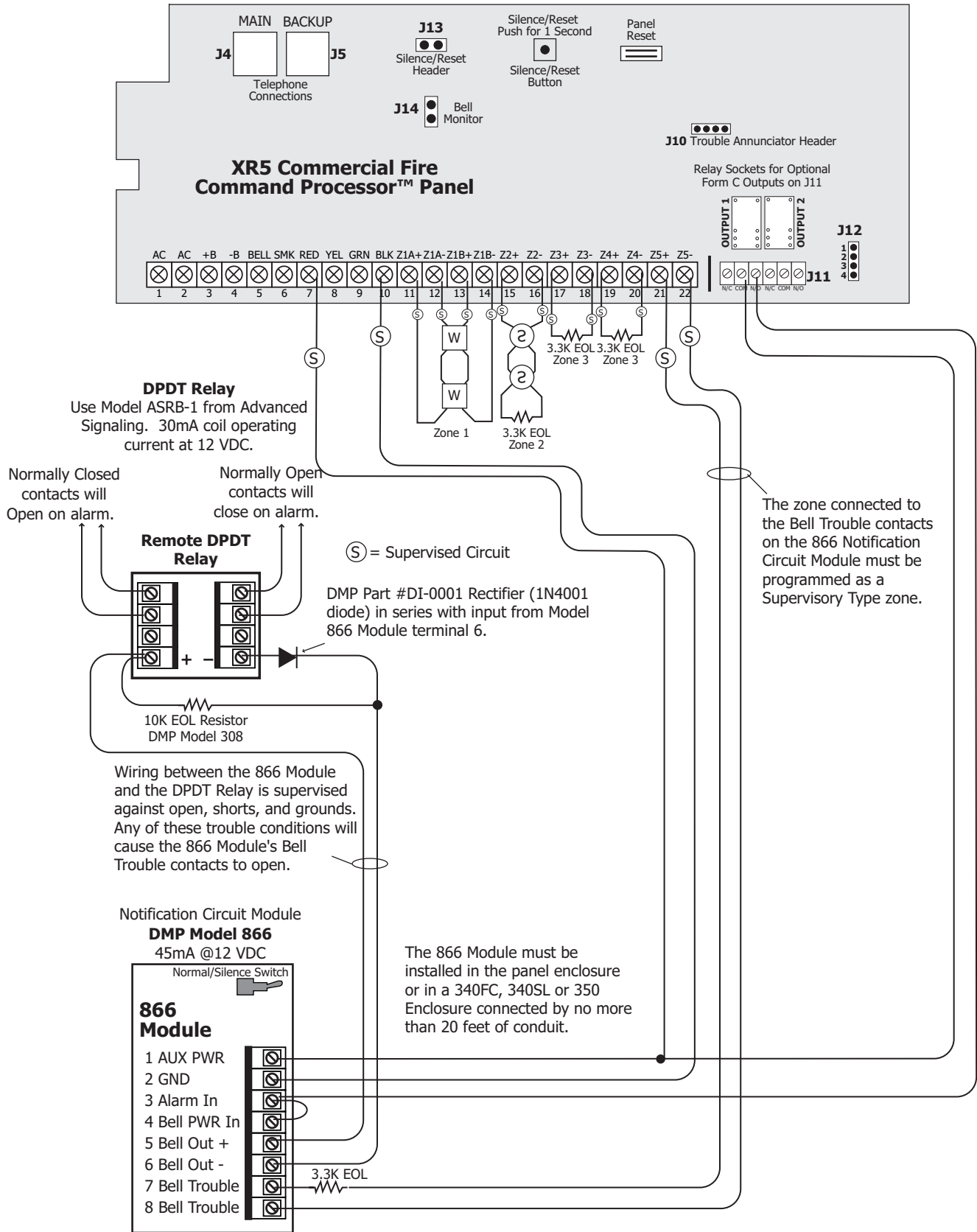

22.11 XR5SL Connection to FACP

AC Mode Wiring

When the XR5SL is used in the AC Mode, the DMP Model 320 Transformer must be connected to the same branch circuit as the FACP.

An AC power fail can then be delayed 6 to 12 hours by the XR5SL programming. See section 5.4 in the XR5 Programming Guide (LT-0312).

The FACP must not indicate AC Fail to the XR5SL.

XR5SL Commercial Fire Command Processor™ Panel

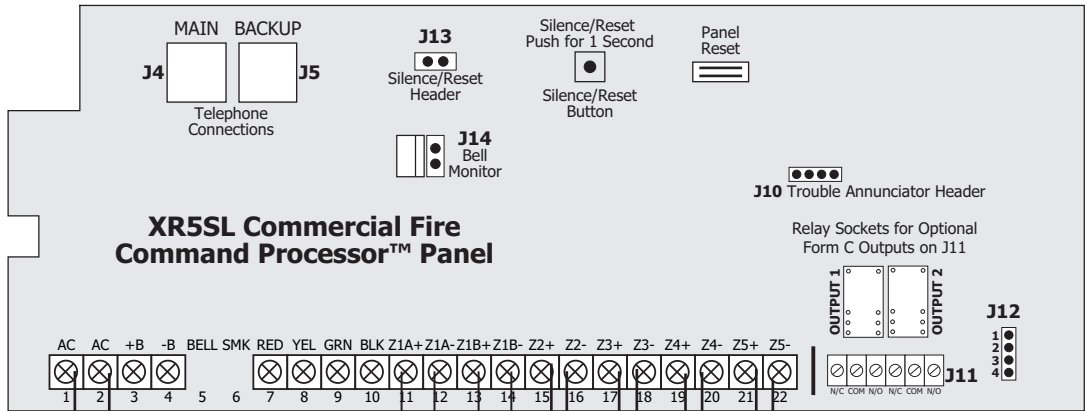

120 VAC
60Hz
350mA

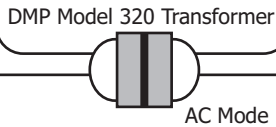

DC Mode Wiring

When the XR5SL is used in the DC Mode, the operating range of the FACP must be between 18 and 30 VDC.

The FACP must indicate AC power fail on an independent relay output. This output must delay the AC power fail at least 1 hour.

Main Fire Alarm Control Panel (FACP)

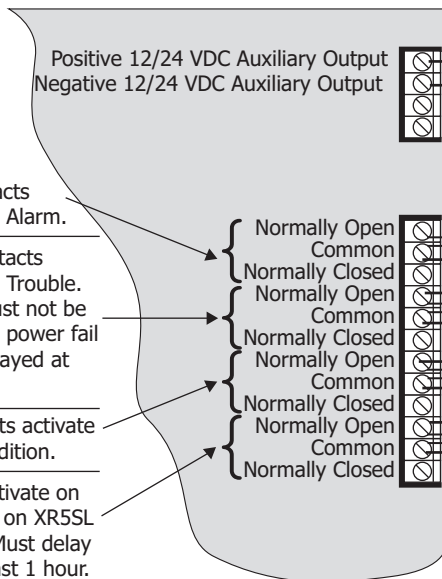

Revisions to This Document

This section explains the changes that were made to this document during this revision. This section lists the date the change was made, the section number and section heading, and a quick summary of the change.

Date	Section Number and Heading	Quick Explanation of Changes
1.01	1.4 Remote Annunciators	Removed reference to no zone expansion supported
	2.2 Zone Expansion	Added section
	2.6 Caution Notes	New section created from Using This Guide
	2.7 Compliance Instructions	Added section
	3.2 and 3.3 Wiring Diagrams	Replaced 690F and 770 keypads with 630F keypad
	3.5 Keypads	Updated to reflect 630F and 692F keypads only
	6.6 Power Requirements	Added 630F, 714, 715, 865, 866, removed obsolete products
	9.1 Keypad Bus Description	Added 630F keypad
	11.1 Class B Fire Zones Description	Added maximum impedance
	14.1 Telephone RJ Connector	Added maximum impedance
	15.1 Reset Jumper J19	Clarified operation
	17.1 Dual Phone Line Connectors	Added maximum impedance
	18.1 Listed Compliance Specifications	Added section
	20.1 Power Supply	Added section
	20.5 Notification Appliances	Added approved notification appliances table
	20.6 Ground Fault	Added section
	22.1 - 21.4 Wiring Diagrams	Added new 866 Notification Appliance diagrams
	21.5 - 21.8 Wiring Diagrams	Added new 865 Notification Appliance diagrams

Listings and Approvals

FCC Part 15
FCC Part 68 Registration ID CCKUSA-18660-AL-R
California State Fire Marshal (CSFM)
New York City (MEA)
Underwriters Laboratories (UL) Listed
Commercial Protected Premises Control Unit
UL 864 Fire Protective Signaling



800-641-4282

www.dmp.com

Made in the USA

INTRUSION • FIRE • ACCESS • NETWORKS

2500 North Partnership Boulevard

Springfield, Missouri 65803-8877

LI-0299 1.01 © 2009 Digital Monitoring Products, Inc.

